

INDITHERM®

Low temperature gas burners



- **High turndown** for maximum operation flexibility.
- Maximum capacities up to 1800 kW.
- Designed for firing in **indirect fired** processes.
- **Excellent combustion** throughout entire capacity range.
- Maximum application **flexibility** with 8 available burner sizes.
- Packaged design for quick and **easy installation**.
- Alternate refractory block materials for **high temperature** applications.

Product description

The INDITHERM® burner is a nozzle-mix burner, suitable for firing natural gas in many industrial indirect-fired applications where clean combustion and a high turndown are required. They offer a simple and versatile answer to a wide variety of applications.

The INDITHERM® burner incorporates a gas and air valve linked together to control the gas/air ratio over the full operating range. The linkage between gas and air valve is internal in the burner and is factory adjusted. No fine tuning or adjustments in the field are required.

To control the capacity, a low torque control motor can be attached directly onto the burner. The burner can accept most commonly used brands and types of control motors.

The required combustion air is provided by an integrated combustion air blower. This blower is mounted directly onto the burner's housing, thus ensuring a good combustion air distribution inside the burner at all times.

The gas enters the burner through the burner gas inlet connection. It flows through the nozzle and then along the inside of the burner mixing cone where combustion air is progressively and tangentially mixed with the gas. This results in a very wide range of turndown and a highly stable flame under a variety of operating conditions.

The burner has an integrated pilot burner with its own flow adjusting orifice. If required the INDITHERM® can be direct ignited without the use of a pilot.

Provision is made for a single UV-scanner to monitor both gas pilot and main flame.

- 1) Burner body
- 2) Burner discharge sleeve
- 3) Combustion air blower
- 4) Spark ignitor
- 5) Flame detector (optional)
- 6) Control motor (optional)
- 7) Connecting bracket and linkage (optional)
- 8) Pilot gas adjusting needle valve (optional)
- 9) High voltage ignition transformer (optional)
- 10) Combustion air pressure connection (Rc1/4")
- 11) Gas inlet

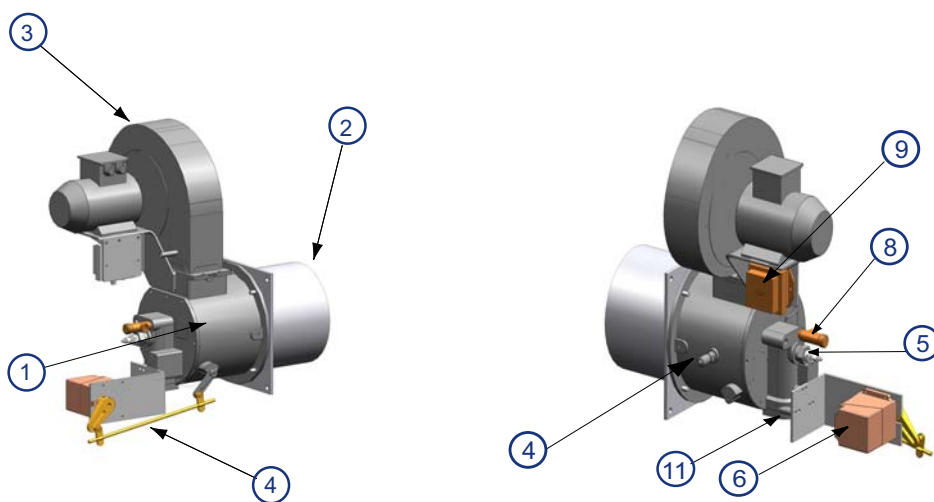

Available INDITHERM® sizes

| Typical burner data | | | | | | | | | |
|--|----------|-----|-----|-----|------|------|------|------|------|
| Fuel: natural gas at 15°C with 10.9 kWh/Nm ³ HHV - sg = 0.6 [1] | | | | | | | | | |
| Combustion air: 15°C - 21% O ₂ - 50% humidity - sg = 1.0 [1] | | | | | | | | | |
| Stated pressures are indicative. Actual pressures are a function of air humidity, altitude, type of fuel, and gas quality. | | | | | | | | | |
| Burner size & type | | 100 | 300 | 550 | 700 | 850 | 1100 | 1500 | 1800 |
| Max. capacity [2] | kW (HHV) | 125 | 340 | 550 | 720 | 850 | 1050 | 1472 | 1800 |
| Min. capacity | kW (HHV) | 5 | 6 | 10 | 15 | 15 | 25 | 25 | 25 |
| Gas pressure [3] | mbar | 3.4 | 7.5 | 6.4 | 10.3 | 13.3 | 19.8 | 5.8 | 10 |
| Flame length [4] | m | 1 | 1.2 | 2 | 2.1 | 2 | 2.3 | 2.6 | 3-4 |

[1] sg (specific gravity) = relative density to air (density air = 1.293 kg/Nm³)

[2] Maximum capacity at 3% O₂ firing, no back pressure in combustion chamber. When firing into a tube under slight over pressure, maximum capacity will be reduced. See "Specifications of INDITHERM® burners" for more information.

[3] Gas pressures for natural gas at burner inlet. The stated pressures should be available at burner inlet throughout the entire capacity range. See "Specifications of INDITHERM® burners" for more information.

[4] Flame lengths are derived from measured lab data. Actual flame lengths can differ slightly.

Every INDITHERM® is available in an ISO and NPT version.



The burner is designed to operate at a 230/400V - 50Hz supply voltage. The burner is designed and factory adjusted to operate at 50Hz. When only 60Hz is available, please contact MAXON.

Applications

Because of its versatility, the INDITHERM® can cover numerous types of applications. All types of indirect-fired applications can be equipped with this simple, industrial burner. Among the major applications there are automotive paint-bake ovens and surface treatment, bakery ovens and dryers for the food industry.

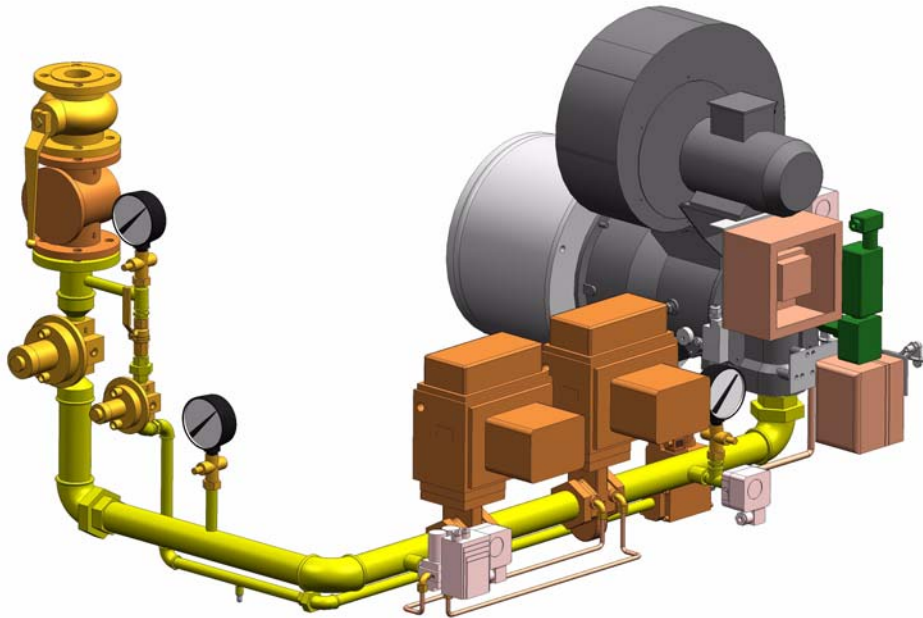

INDITHERM® 1100 gas burner with natural gas pipe train, including MAXON 5000 shut off valves. System used on paint dry ovens in automotive industry.

Dimensions and weights

INDITHERM® - all sizes

1) Gas inlet

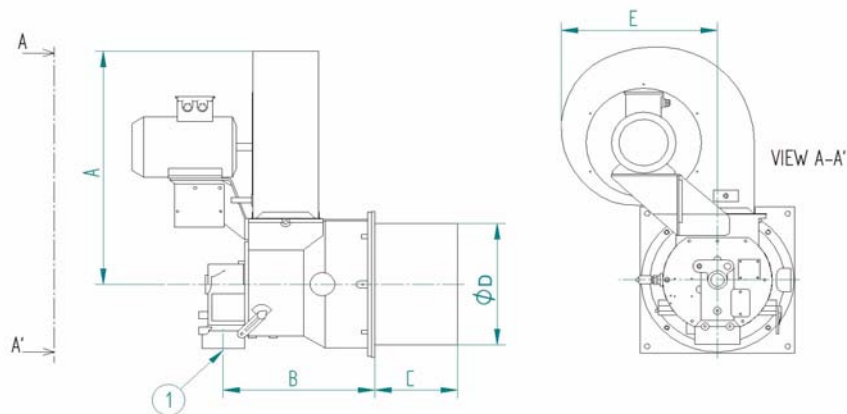

| Dimensions in mm unless stated otherwise | | | | | | | |
|--|---------------|-----|-------|-----|--------|-----|-----------------|
| Burner size | Gas inlet [1] | A | B [2] | C | ØD [2] | E | Weight (kg) [3] |
| 100 | 1" | 365 | 225 | 200 | 160 | 224 | 30 |
| 300 | 1 1/4" | 365 | 224 | 200 | 210 | 224 | 34 |
| 550 | 1 1/2" | 514 | 255 | 200 | 260 | 308 | 50 |
| 700 | 2" | 598 | 255 | 200 | 260 | 387 | 50 |
| 850 | 2" | 598 | 255 | 200 | 260 | 387 | 50 |
| 1100 | 2" | 597 | 365 | 200 | 311 | 387 | 71 |
| 1500 | 2" | 597 | 365 | 200 | 311 | 387 | 71 |
| 1800 | 3" | 659 | 365 | 200 | 311 | 451 | 71 |

[1] Gas connections are threaded (NPT or ISO)

[2] These dimensions only apply when a standard discharge sleeve is used. Refer to "Specifications of INDITHERM® burners" in case refractory sleeve will be used and for more detailed dimensions.

[3] The weight applies for burners with standard discharge sleeve. Burners with high temperature refractory sleeve will have significantly higher weights. Refer to "Specifications of INDITHERM® burners".

Specifications of INDITHERM® burners

| Typical burner data | | | | | | | | | | |
|--|-------------------|---------------------------|-----|------|-----|------|------|------|------|------|
| Fuel: natural gas at 15° C with 10.9 kWh/Nm ³ HHV - sg = 0.6 [1] | | | | | | | | | | |
| Combustion air: 15° C - 21 % O ₂ - 50 % humidity - sg = 1.0 [1] | | | | | | | | | | |
| Stated pressures are indicative. Actual pressures are a function of air humidity, altitude, type of fuel, and gas quality. | | | | | | | | | | |
| Burner size & type | | | 100 | 300 | 550 | 700 | 850 | 1100 | 1500 | 1800 |
| | | back pressure [2] mbar | | | | | | | | |
| Max. capacity [3] | kW (HHV) | 0 | 125 | 340 | 550 | 720 | 850 | 1050 | 1472 | 1800 |
| | | 1.5 | 110 | 285 | 500 | 675 | 775 | 880 | 1266 | 1693 |
| Min. capacity [4] | kW (HHV) | 0- 1.5 | 5.0 | 6.0 | 10 | 15 | 15 | 25 | 25 | 25 |
| Pilot capacity [5] | kW (HHV) | 0-1.5 | 7.5 | 10.0 | 15 | 25 | 25 | 40 | 40 | 40 |
| Combustion air differential pressure [6] | mbar | 0 | 6.5 | 4.5 | 6.4 | 7.9 | 9 | 5 | 6.4 | 13 |
| | | 1.5 | 5 | 3.2 | 5 | 7.3 | 7.5 | 3.5 | 4.7 | 11.5 |
| Combustion air flow | m ³ /h | 0 | 136 | 360 | 615 | 755 | 910 | 1100 | 1611 | 1850 |
| | | 1.5 | 119 | 304 | 545 | 728 | 831 | 920 | 1386 | 1740 |
| Gas differential pressure at inlet [7] | mbar | 0 | 3.4 | 7.5 | 6.4 | 10.3 | 13.3 | 19.8 | 5.8 | 10 |
| Gas differential pressure at test connection [8] | mbar | 0 | 2.7 | 6.7 | 5.4 | 7.1 | 12 | 17.7 | 5.5 | 9.3 |
| | | 1.5 | 2.1 | 4.7 | 4.5 | 6.3 | 10 | 12.4 | 4 | 8.2 |
| Flame length [9] | m | 0-1.5 | 1 | 1.2 | 2 | 2.1 | 2 | 2.3 | 2.6 | 3-4 |

[1] sg (specific gravity) = relative density to air (density air = 1.293 kg/Nm³).

[2] Back pressure = static pressure in the combustion chamber where the flame develops. Data in this table are given for 0 and 1.5 mbar back pressure. Combustion air flow valid for all listed maximum capacities.

[3] Maximum capacity when firing at 3% vol. O₂ level in the flue gas.

[4] Minimum capacity without pilot gas. If lower minimum capacities are required, refer to chapter 'minimum capacities' in this section.

[5] With direct ignition (no pilot), start capacity should be equal or higher than the stated pilot capacity.

[6] Differential pressure measured between burner test connection and combustion chamber.

[7] Gas differential pressures for natural gas at burner inlet. This pressure should be available at burner inlet throughout the entire capacity range.

[8] Differential pressure to be measured between burner test connection and combustion chamber.

[9] Flame lengths are derived from measured lab data. Actual flame lengths can differ slightly.

Materials of construction

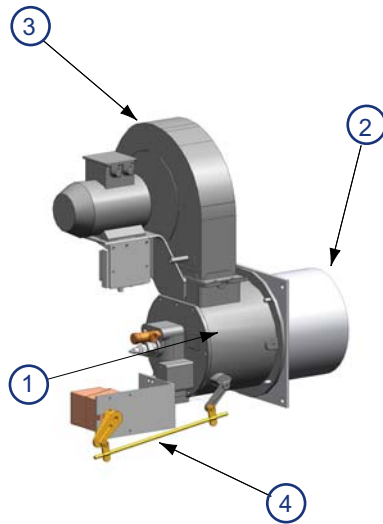

| | | |
|---|------------------------|---------------------|
| 1 | Housing | Cast iron |
| 2 | Standard sleeve | AISI 310 (1.4841) |
| | High temperature block | Castable refractory |
| 3 | Blower housing | Carbon steel |
| 4 | Motor mounting bracket | Carbon steel |

Selection criteria

Application details

Because of the burner's versatility there are numerous types of applications for INDITHERM® burners. All types of indirect-fired applications can be equipped with this simple, industrial burner. Among the major applications there are automotive paint-bake ovens and surface treatment, bakery ovens and dryers for the food industry.

Available INDITHERM® burner versions and options

INDITHERM® burners are designed to operate on natural gas only.

All burners are available in ANSI and ISO version. Each version will have the main gas inlet connection following either NPT or ISO standards.

All burners include an adjustable orifice needle valve for pilot flame fine tuning, provision for UV-scanner connection and a stainless steel combustion sleeve.

Options

Every burner has a set of options available, according to the table below:

| | |
|-----|--|
| HTS | High temperature discharge sleeve |
| FLR | Combustion air filter box, recommended in extremely dusty surroundings |
| DI | Direct ignited: in this case the adjustable orifice will be removed and the pilot connection at the burner will be plugged |
| UVC | Burner flame scanner connection prepared for UV-scanner mounting (scanner not included) |
| CBL | Connecting bracket and linkage for control motor mounting (control motor make and type to be specified) |

Exception:

| | |
|----|---|
| FR | Flame rod, only to be used in limited number of applications, see page 1-2.3-11 |
|----|---|



The spark ignitor is standard included on the burner.

Burner designation

| Burner type | Burner size | Burner gas connection | Discharge sleeve | Ignition | Flame supervision |
|-------------|-------------|-----------------------|------------------|----------|-------------------|
| INDITHERM® | 300 | ISO | HTS | DI | UVC |

Burner size

100
300
550
700
850
1100
1500
1800

Discharge sleeve

HTS: High temperature
STD: standard version, stainless steel

Ignition

DI: Direct Ignition (plugged pilot port)
PL: Pilot burner

Flame supervision

UVC: prepared for UV-scanner mounting
FRC: prepared for flame rod mounting

Burner gas connection

ISO: ISO threaded
NPT: NPT threaded

Fuels

INDITHERM® burners are designed to operate on natural gas. For propane and butane operation a standard INDITHERM® burner can not be used. Contact MAXON when the use of gases other than natural gas is inevitable.

Burner discharge sleeve

The burner discharge sleeve is available in different materials and geometries:

- **Standard version** with circular stainless steel discharge sleeve and square burner mounting plate.
- **High temperature version** with refractory block for installation in applications where high temperatures can be expected.

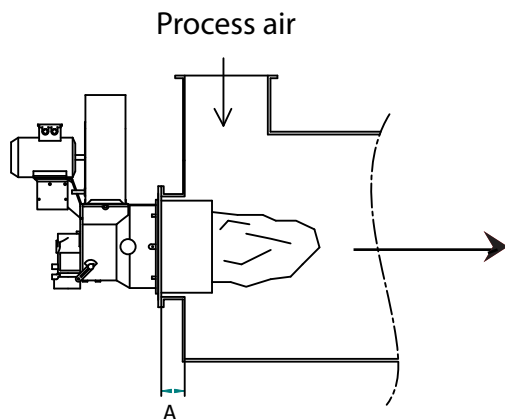

In following cases the use of high temperature version discharge sleeve is required:

- Dimension A is larger than 50mm
- Insufficient low temperature process air is available to cool the discharge sleeve
- No process air is available (typical in indirect fired applications)
- Process air is entered downstream of the burner, being unable to flow over the burner discharge sleeve

Control motor mounting plate

The INDITHERM® burner can be equipped with an electrical or pneumatic control motor for capacity control. A broad range of mounting plates are available to accept almost any common control motor on the market. Required torque = 1.2 Nm.

Maximum capacities

INDITHERM® burners will have different maximum capacities depending on burner size and application back pressure. Refer to table on page 1-2.3-6 for maximum capacities.

Capacities are stated for firing at zero back pressure and for 1.5 mbar back pressure, both at 3 % O₂ level in the exhaust gases.

Minimum capacities

The minimum capacities depend on burner size and can be found in the table at page 1-2.3-6. The capacities in this table are those that still allow a stable flame on main gas. When lower capacities are required, using a continuous pilot can be a solution. In this case, the internal gas control valve of the burner can be closed even more at minimum position, while the minimum required gas flow to maintain a stable flame can be adjusted using a needle valve on the pilot gas.

Preheated air

The INDITHERM® burner is designed to operate with non preheated combustion air. Although, the burner materials are suitable to withstand up to 200° C temperatures, the burner will not perform according to the specifications page page 1-2.3-6 when the combustion air is preheated. Contact MAXON for more details.

Process temperature

The high temperature refractory block permits operation of combustion chamber temperatures up to 950 °C . When using a standard discharge sleeve, proper circulation of cold process air around the entire discharge sleeve should be present at all times.

Piloting and ignition

INDITHERM® burners have an internal pilot burner. Piloting is accomplished by internally bypassing the built-in gas butterfly valve which is in the minimum position at low fire. The pilot gas is admitted to the gas nozzle via the main gas conduit and is injected through the same gas nozzle ports as the main gas. The pilot gas adjusting valve allows for easy and precise adjusting of the pilot flame.

The use of an intermittent pilot is technically possible on this burner and could result in lower minimum capacities.

Use minimally 5000 V/200 VA ignition transformers for sparking of the spark ignitor. Locate pilot gas valves as close as possible to the pilot burner gas inlet, to have fast ignition of the pilot burner. When igniting the main gas, the capacity rating of the burner at that point shall be limited.

Direct ignition

In case the use of a pilot burner is not required, the INDITHERM® burner can be direct ignited on main gas.

The pilot gas inlet should be plugged. When direct igniting an INDITHERM® burner, the capacity setting during ignition should be limited. Direct ignition at high capacity is not allowed.

Typical ignition sequences

- Pre purge of burner and installation, according to the applicable codes and the installation's requirements.
- Burner capacity control valve shall be in the start position to allow minimum combustion air flow to the burner.
- Pre-ignition (typically 2 s sparking in air).
- Open pilot gas and continue to spark the igniter (typically 5 s).
- Stop sparking, continue to power the pilot gas valves and start flame check.
- Check pilot flame stability (typical 5 s to prove the stable pilot).
- Open main gas valves and allow enough time to have main gas in the burner. (typical 5 s + time required to have main gas in the burner).
- Close the pilot gas valves.
- Release to modulation (allow modulation of the burner).
- Above sequences shall be completed to include all required safety checks during the start-up of the burner (process & burner safeties).

Flame supervision

Flame supervision can be accomplished by use of a UV-scanner for all INDITHERM® burners and sizes. The scanner connection is 1". Due to the presence of gas at the scanner port, only tight scanners can be used.

The use of a flame rod is only possible in a limited range of applications where the standard discharge sleeve is used. A flame rod combined with a high temperature discharge sleeve would generate a flame signal too low for proper flame scanning. Contact MAXON for more details when considering a flame rod.

Flame development

INDITHERM® burners shall be installed in combustion chambers that allow full development of the burner flame. Consult MAXON for proper combustion chamber lay-out.

Gas pipe train design

The INDITHERM® burner is very sensitive to variations in gas pressures at burner gas inlet. The burner gas inlet pressure should not vary more than 2.5 mbar between high and low capacity.

Process back pressures

The INDITHERM® burner can operate between 0 and 1.5 mbar back pressure. The burner should not be used on applications where back pressures would fall outside these limits. It is possible to mount the burner on a process with changing back pressures as long as the fluctuating pressures stay within the 0 to 1.5 mbar limit.

Measuring equipment for burner commissioning

The burner gas pressures and air pressures as mentioned in table on page 1-2.3-6 should be used as a guideline for burner system design and to have an approximative value for burner set up. To adjust the burner properly during commissioning, the oxygen content in the flue gas should be measured. A properly adjusted burner in an indirect fired application should have approximately 3% O₂ in the stack at maximum capacity.

Dimensions

INDITHERM® with standard discharge sleeve - all sizes

- 1) Gas inlet
- 2) Pilot gas connection
- 3) Combustion air test connection
- 4) Gas pressure test connection
- 5) 90° capacity control crank
- 6) Filter housing (optional)
- 7) Stainless steel discharge sleeve (standard)
- 8) Flame supervision port
- 9) Spark ignitor

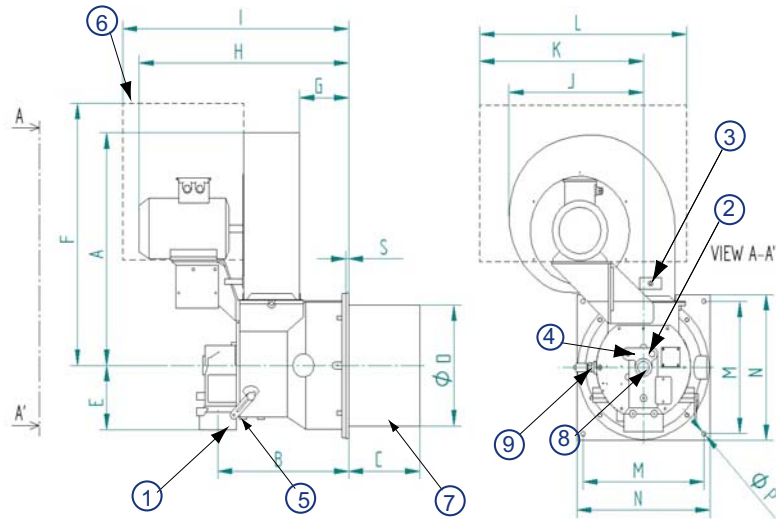

| Dimensions in mm unless stated otherwise | | | | | | | | | | | | | | | | | | |
|--|---------------|-----|-----|-----|-----|-----|-----|-----|-----|-----|-----|-----|-----|-----|-----|----|---|-------------|
| burner size | gas inlet [1] | A | B | C | ØD | E | F | G | H | I | J | K | L | M | N | ØP | S | Weight (kg) |
| 100 | 1" | 365 | 225 | 200 | 160 | 111 | 442 | 93 | 390 | 431 | 224 | 289 | 353 | 184 | 214 | 13 | 5 | 30 |
| 300 | 1 1/4" | 365 | 224 | 200 | 210 | 111 | 442 | 91 | 390 | 431 | 224 | 289 | 353 | 226 | 264 | 13 | 5 | 34 |
| 550 | 1 1/2" | 514 | 255 | 200 | 260 | 138 | 541 | 100 | 435 | 462 | 308 | 367 | 400 | 286 | 318 | 13 | 8 | 50 |
| 700 | 2" | 598 | 255 | 200 | 260 | 138 | 786 | 71 | 435 | 500 | 387 | 403 | 448 | 286 | 318 | 13 | 8 | 50 |
| 850 | 2" | 598 | 255 | 200 | 260 | 138 | 777 | 71 | 465 | 498 | 387 | 403 | 448 | 286 | 318 | 13 | 8 | 50 |
| 1100 | 2" | 597 | 365 | 200 | 311 | 165 | 777 | 136 | 560 | 593 | 387 | 403 | 448 | 340 | 375 | 13 | 8 | 70 |
| 1500 | 2" | 597 | 365 | 200 | 311 | 165 | 777 | 136 | 560 | 593 | 387 | 403 | 448 | 340 | 375 | 13 | 8 | 70 |
| 1800 | 3" | 659 | 365 | 200 | 311 | 165 | 809 | 136 | 605 | 663 | 451 | 452 | 480 | 340 | 375 | 13 | 8 | 70 |

[1] gas inlet is threaded, available in ISO or NPT.

INDITHERM® with high temperature discharge sleeve - all sizes

- 1) Gas inlet
- 2) Pilot gas connection
- 3) Combustion air test connection
- 4) Gas pressure test connection
- 5) 90° capacity control crank
- 6) Filter housing (optional)
- 7) High temperature discharge sleeve
- 8) Flame supervision port
- 9) Spark ignitor

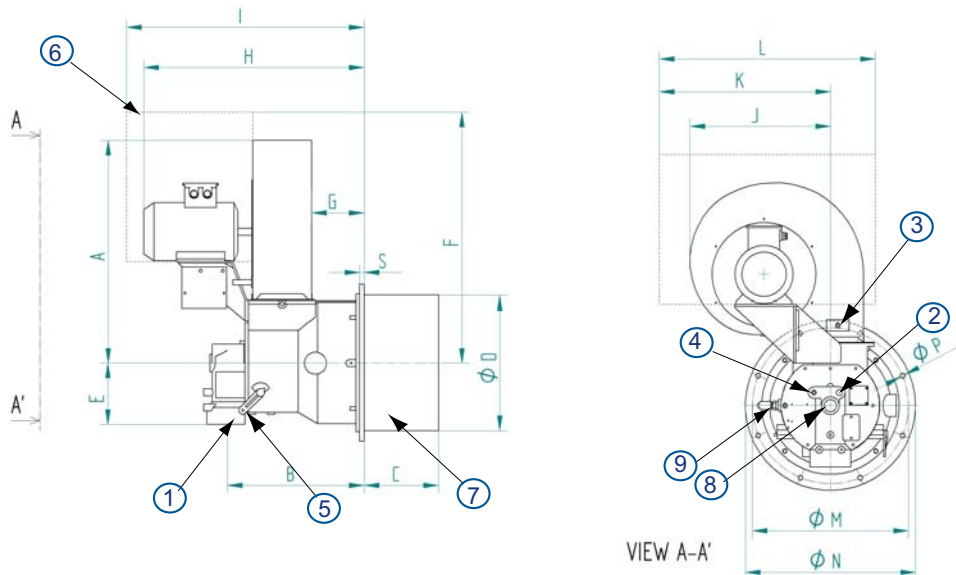

| Dimensions in mm unless stated otherwise | | | | | | | | | | | | | | | | | | |
|--|---------------|-----|-----|-----|-----|-----|-----|-----|-----|-----|-----|-----|-----|-----|-----|----|----|-------------|
| burner size | gas inlet [1] | A | B | C | ØD | E | F | G | H | I | J | K | L | ØM | ØN | ØP | S | Weight (kg) |
| 100 | 1" | 365 | 232 | 200 | 257 | 111 | 442 | 100 | 397 | 438 | 224 | 289 | 353 | 320 | 357 | 14 | 12 | 47 |
| 300 | 1 1/4" | 365 | 231 | 200 | 305 | 111 | 442 | 98 | 397 | 438 | 224 | 289 | 353 | 368 | 405 | 14 | 12 | 57 |
| 550 | 1 1/2" | 514 | 259 | 200 | 357 | 138 | 541 | 104 | 439 | 466 | 308 | 367 | 400 | 420 | 457 | 14 | 12 | 83 |
| 700 | 2" | 598 | 259 | 200 | 357 | 138 | 786 | 75 | 439 | 504 | 387 | 403 | 448 | 420 | 457 | 14 | 12 | 83 |
| 850 | 2" | 598 | 259 | 200 | 357 | 138 | 777 | 75 | 469 | 502 | 387 | 403 | 448 | 420 | 457 | 14 | 12 | 83 |
| 1100 | 2" | 597 | 369 | 200 | 408 | 165 | 777 | 140 | 564 | 597 | 387 | 403 | 448 | 471 | 508 | 14 | 12 | 110 |
| 1500 | 2" | 597 | 369 | 200 | 408 | 165 | 777 | 140 | 564 | 597 | 387 | 403 | 448 | 471 | 508 | 14 | 12 | 110 |
| 1800 | 3" | 659 | 369 | 200 | 408 | 165 | 809 | 140 | 609 | 667 | 451 | 452 | 480 | 471 | 508 | 14 | 12 | 110 |

[1] Gas inlet is threaded, available in ISO or NPT.

Adjustable orifice for pilot burner - ADJ-ORF

This orifice is standard included with the burner and is factory mounted onto the burner pilot gas port. In case a burner has been ordered for direct ignition, this adjustable orifice is omitted.

- 1) Gas outlet 3/8" NPT
- 2) Gas inlet 3/8" NPT
- 3) Protection cap: remove to access flow adjustment screw
HEX 3.8 mm

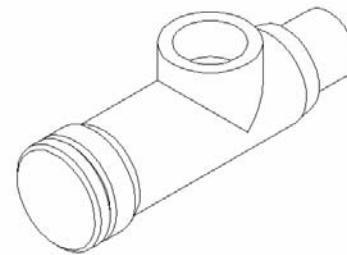
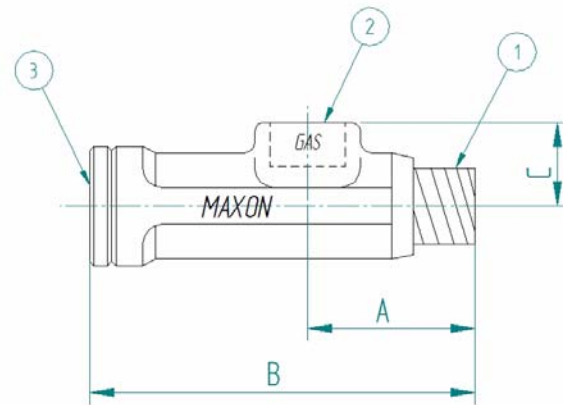

| A | B | C |
|-------|---------|-------|
| 38 mm | 87.5 mm | 19 mm |

Two available versions depending on burner size:

- ADJ-ORF-STD: with standard drilling for burner sizes 100 and 300
- ADJ-ORF-HC: with larger internal drilling for burner sizes 550 and up

Spark ignitor - SI-1/2

The spark ignitor is standard included with the burner. It is advised to keep at least one additional spark ignitor available as a spare item for maintenance.

This spark ignitor can be mounted directly onto the burner spark ignitor connection port.

To be used on all burner sizes. See table below for mounting position C depending on burner size.

1) 1/2" NPT

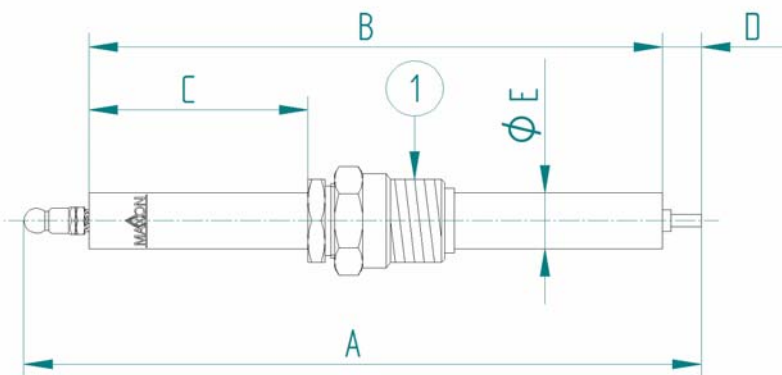

| Dimensions in mm unless stated otherwise | | | | | |
|--|-----|-----|----|---|-----|
| burner size | A | B | C | D | Ø E |
| 100 | 165 | 140 | 33 | 5 | 14 |
| 300 | 165 | 140 | 37 | 5 | 14 |
| 550-850 | 165 | 140 | 31 | 5 | 14 |
| 1100-1800 | 165 | 140 | 33 | 5 | 14 |

Filter Elements - FLT- INDI

Replacement elements for the optional INDITHERM® burners combustion air filters. Available in 4 types to cover all burner sizes.

- FLT-INDI-1 for burner sizes 100 and 300
- FLT-INDI-2 for burner size 550
- FLT-INDI-3 for burner sizes 700-850-1100-1500
- FLT-INDI-4 for burner size 1800

Gaskets - GSK- INDI

These gaskets are used to seal the mounting plate of the burner and the duct wall. Optionally available in 2 different types:

- GSK-INDI-STD to be used in combination with standard discharge sleeves (square)
- GSK-INDI-HT to be used in combination with high temperature discharge sleeves (round)

| Gasket type | Burner Type | Geometry |
|----------------|-------------|----------|
| GSK-INDI-STD-1 | 100 | square |
| GSK-INDI-STD-2 | 300 | square |
| GSK-INDI-STD-3 | 550-850 | square |
| GSK-INDI-STD-4 | 1100-1800 | square |
| GSK-INDI-HT-1 | 100 | round |
| GSK-INDI-HT-2 | 300 | round |
| GSK-INDI-HT-3 | 550-850 | round |
| GSK-INDI-HT-4 | 1100-1800 | round |

Installation and operation instructions for INDITHERM® burners

Application requirements

Supporting burner air and gas piping

The INDITHERM® burner shall not be used as support for the piping to the burner. Gas and air piping shall be supported in such a way that no additional loads will be created on the burner.

Burner mounting flange loads

Check burner weight and reinforce burner mounting flange or combustion chamber/furnace back wall if necessary to support the complete burner weight.

Installation instructions

Storage of INDITHERM® burners

INDITHERM® burners shall be stored dry (inside). Burner blocks have been cured carefully before shipment and shall be kept dry. Wetting of the blocks could result in premature failures.

Handling of INDITHERM® burners

INDITHERM® burners are shipped as complete units. Handle burners with care, using proper equipment during unpacking, transport, lifting and installation. Any impact on the burner could result in damage. To prevent damage in transit, accessories such as flame rods, control valves, UV-scanners, may be packed separately and shipped loose.

Orientation of INDITHERM® burners

INDITHERM® burners can be mounted and fired in any direction. However we advise to avoid orientations which can permit flame supervision ports to collect debris and/or moisture. Also check limitations on orientation of other components mounted on the burner head.

Burner mounting

Bolt the burner to the installation's burner mounting flange. Use proper gaskets between burner and burner mounting flange (option available). Tighten the flange bolting with correct torque. Retighten all bolts after first firing and regularly after commissioning.

INDITHERM® with standard sleeve

- 1) oven wall
- 2) mounting studs
- 3) gasket
- 4) burner

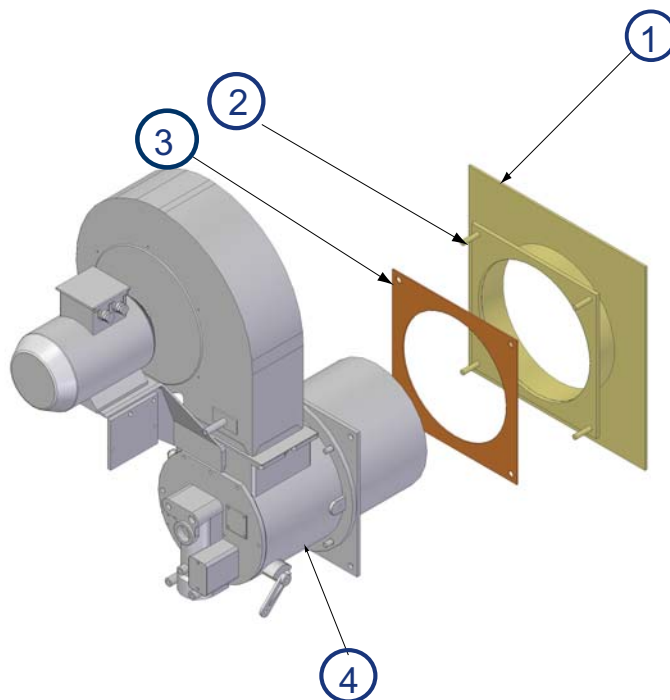

INDITHERM® with block with seal and support housing

- 1) oven wall
- 2) mounting studs
- 3) gasket
- 4) burner

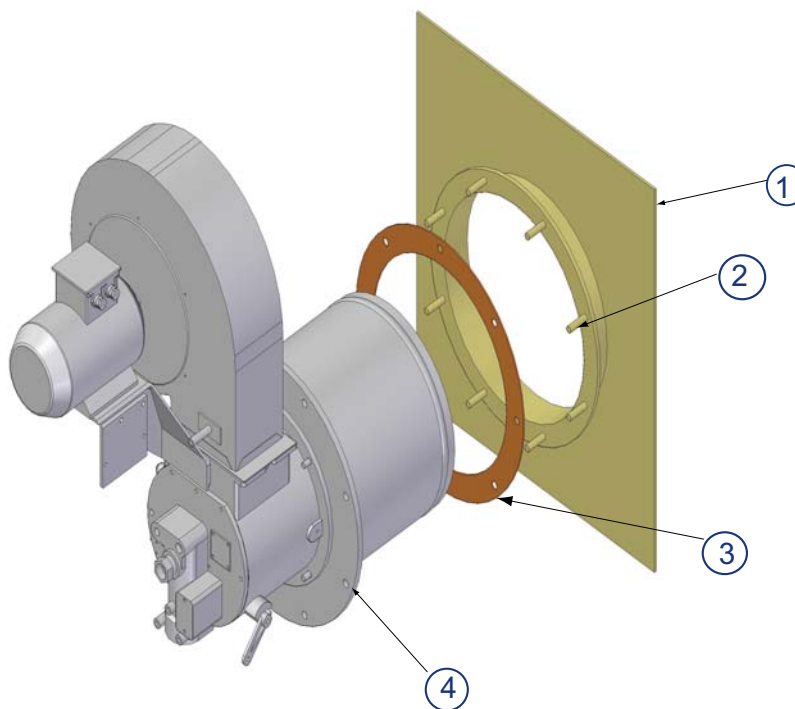

Burner mounting flange

Refer to below figure to design a correct burner mounting flange on the installation.

Mounting flange for INDITHERM® burners with standard sleeve

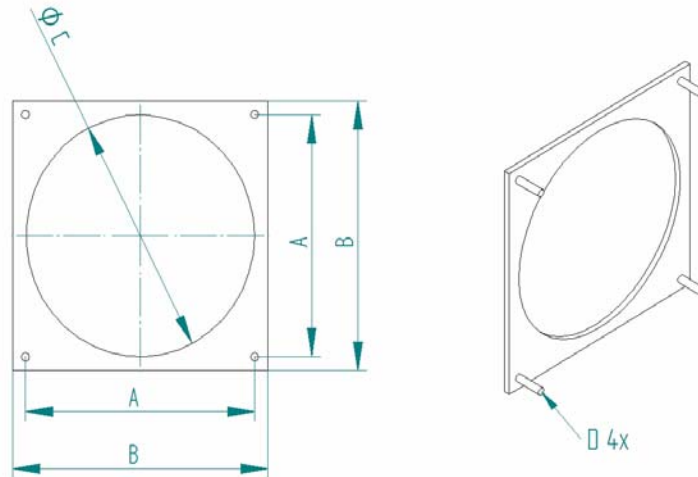

| Dimensions in mm unless stated otherwise | | | | |
|--|-----|-----|-----|-----|
| Burner size | A | B | ØC | D |
| 100 | 184 | 214 | 185 | M10 |
| 300 | 226 | 264 | 235 | M10 |
| 550 | 286 | 318 | 285 | M10 |
| 700 | 286 | 318 | 285 | M10 |
| 850 | 286 | 318 | 285 | M10 |
| 1100 | 340 | 375 | 336 | M10 |
| 1500 | 340 | 375 | 336 | M10 |
| 1800 | 340 | 375 | 336 | M10 |

Mounting flange for INDITHERM® burners with high temperature block sleeve

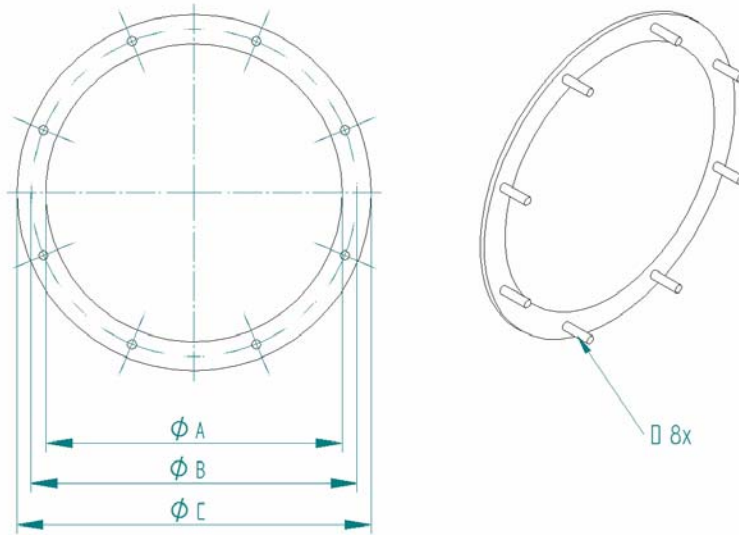

| Dimensions in mm unless stated otherwise | | | | |
|--|-----|-----|-----|-----|
| Burner size | ØA | ØB | ØC | D |
| 100 | 282 | 320 | 357 | M12 |
| 300 | 330 | 368 | 405 | M12 |
| 550 | 382 | 420 | 457 | M12 |
| 700 | 382 | 420 | 457 | M12 |
| 850 | 382 | 420 | 457 | M12 |
| 1100 | 433 | 471 | 508 | M12 |
| 1500 | 433 | 471 | 508 | M12 |
| 1800 | 433 | 471 | 508 | M12 |

Start-up instructions for INDITHERM® burners

Instructions provided by the company or individual responsible for the manufacture and/or overall installation of a complete system incorporating MAXON burners take precedence over the installation and operating instructions provided by MAXON. If any of the instructions provided by MAXON are in conflict with local codes or regulations, please contact MAXON before initial start-up of equipment.



Read the combustion system manual carefully before initiating the start-up and adjustment procedure. Verify that all of the equipment associated with and necessary to the safe operation of the burner system has been installed correctly, that all pre-commissioning checks have been carried out successfully and that all safety related aspects of the installation are properly addressed.

Initial adjustment and light-off should be undertaken only by a trained commissioning engineer.

■ First firing or restart after shut-down

During first start-up of the burner, allow extended period at low firing range to minimize potential damage from accumulated and retained moisture in refractory burner block.

During cold starts, the temperature rise shall be limited – allow the burner to fire on low fire for some time to allow the parts to heat up slowly for maximum life.

■ Safety interlocks

Guarantee that all the required safety locks as described in the applicable local codes or regulations, or supplementary safety blocks requested for safe operation of the overall installation, are working properly and resulting in a positive safety-lock of the burner. Do not bypass any of these safety interlocks, this will result in unsafe operation.

■ Checks during and after start up

During and after start-up, check the integrity of the system. Check all bolted connections after first firing (first time on temperature) and retighten if necessary.

■ Purge

For safety reasons, it is required to purge the installation sufficiently long to ensure that all possible combustibles are evacuated before ignition. Refer to the applicable local codes and your specific application requirements to determine the purge time.

■ Pilot ignition

Adjust pilot air flow and pilot gas regulator to correct set point before pilot ignition attempt. Turn adjustable orifice screw out (counter-clockwise) several turns from its fully seated position. Refine during lighting of the pilot to a yellow/blue flame and/or strongest stable flame signal.

■ Main burner ignition

Adjust the main gas regulator at the correct set point before igniting the main burner. Ensure that the gas/air ratio valve is in the start position when lighting the main burner.

After ignition of main burner, allow some time on minimum capacity to allow the burner parts to heat up slowly.

■ Burner adjustment

Once the main flame is ignited, adjust gas pressure to the burner to have the required combustion quality. Slowly increase capacity while observing the flame and measuring flue gas quality. Do not increase capacity too fast to avoid damage to burner parts or furnace due to excessive temperature gradient.

Maintenance and inspection

Safety requirements

Regular inspection, testing and recalibration of combustion equipment according to the installation's manual are an integral part of its safety. Inspection activities and frequencies shall be carried out as specified in the installation's manual. Perform the following activities at least annually as part of a recommended preventative maintenance routine:

- Inspect burner internal parts for wear and oxidation, paying special attention to the refractory of the burner block (when applicable).
- Inspect associated control instruments and devices for function with particular attention to all safety permissive switches.
- Perform leak tests on fuel shut off valves according to any schedule established by the authority having jurisdiction.

Visual inspections

Regular visual inspection of all connections (air and gas piping to the burner, bolting of the burner mounting flange and burner flame shape and aspect are essential for safe operation.

Recommended spare parts

Keep local stock of spark igniter. It is not recommended to keep local stock of other burner parts. Consult installation manual for burner spare parts and system accessories.