

# SERIES 35-53



## 12 VDC Microprocessor Based Direct Spark Ignition Control

35.53.02

### FEATURES

- *Optional combustion blower relay with selectable postpurge*
- *System diagnostic LED indicator*
- *Multiple tries for ignition (TFI)*
- *Automatic reset 1 hour after lockout*
- *Custom TFI, prepurge and interpurge timings*
- *Remote or local flame sensing*
- *Software conforms to UL 1998 requirements*
- *Safe start*
- *Heavy conformal coating*

### APPLICATIONS

- *Recreational Vehicles (including boats/marine)*
- *Infrared Paving Repair Equipment*
- *Outdoor Torches and Lanterns*
- *Battery Powered Furnaces & Appliances*



### DESCRIPTION

The Model 35-53 is a 12 VDC Microprocessor Based Direct Spark Ignition Control designed for use in all types of heating applications such as RV gas furnaces and other similar appliances. The control utilizes a microprocessor to continually and safely monitor, analyze and control the proper operation of the gas burner. Value added features such as combustion blower control, LED diagnostic output, and multiple ignition tries highlight the control's benefits. Combustion blower versions are fully backward compatible with all previous Fenwal 12VDC controls and competitive models. The control determines the unit configuration at the start of the heating sequence and disables the blower function if not required, allowing one part to address all service or OEM needs.

### Agency Certifications

 Design certified to UL372, File MH8817

 Design certified to ANSI Z21.20-1998 and CAN/CSA C22.2 No. 199-M89 - Report # C2180012

### SPECIFICATIONS

| INPUT VOLTAGES                | DESCRIPTION   |
|-------------------------------|---|
| Input Power                   | Control: 9.0 to 15 VDC from a storage battery or full wave rectified unfiltered 50/60 Hz AC     |
| Input Current Drain           | 300 mA @ 12 VDC, combustion blower and gas valve relays energized (control only)                |
| Gas Valve Rating              | 1.0A @ 12 VDC   |
| Combustion Blower Rating      | 20.0A @ 12 VDC  |
| Operating Temperature         | -40°F to +176°F ( -40°C to +80°C)   |
| Flame Sensitivity             | 0.7µA minimum   |
| Flame Failure Response Time   | 0.8 seconds maximum   |
| Types of Gases                | Natural, LP, or manufactured  |
| Spark Rate                    | 16 sparks per second  |
| Size (LxWxH)                  | 4.25 x 3.25 x 1.80 inches<br>10.80 x 8.25 x 4.57 cm   |
| Enclosure                     | Uncovered with integral standoffs or optional cover   |
| Moisture Resistance           | Conformal coated to operate to 95% R.H. Always avoid direct exposure to water                   |
| Tries for Ignition            | One or three try versions available   |
| Trial for Ignition Period     | 5.0, 7.0, 10.0, or 25.0 seconds available   |
| Prepurge & Interpurge Timings | None, 15 or 25 seconds depending on model. Without prepurge there is a 1 second start-up delay. |
| Postpurge Timings             | Selectable 45, 90, 130, 150 seconds   |

# SEQUENCE OF OPERATION / FLAME RECOVERY/ SAFETY LOCKOUT

## Start up - Heat Mode

When a call for heat is received from the thermostat supplying 12 volts to TH, the control will reset, perform a self check routine and verify no flame exists (safe start). After verifying the airflow switch input is open, the Blower is energized and the airflow switch contacts close starting the pre-purge delay. After the pre-purge delay the gas valve is energized and sparks commence for the trial for ignition period.

When flame is detected during the trial for ignition, sparking stops and the gas valve remains energized. The thermostat, airflow switch and main burner flame are constantly monitored to assure that the system continues to operate properly. When the thermostat is satisfied and the demand for heat ends, the main valve is de-energized immediately, and after the post-purge period the blower is turned off.

## Failure to Light - Lockout

### MULTI TRIAL MODEL

Should the main burner fail to light, or if the flame is not detected during the first trial for ignition period, the gas valve is de-energized and the control goes through an interpurge delay before another ignition attempt. The control will attempt two additional ignition trials before going into lockout after which the valve relay will remain de-energized and the blower will turn off after a five minute delay.

### SINGLE TRIAL MODEL

Should the main burner fail to light, or flame is not detected during the trial for ignition period, the control will go into lockout. The valve will be turned off immediately and the blower will turn off after a five minute delay.

Recovery from lockout requires a manual reset by either resetting the thermostat or removing 12 volt power for a period of 5 seconds.

If the thermostat is still calling for heat after one hour the control will automatically reset and attempt to ignite the burner again.

## Flame Failure

If the established flame signal is lost while the burner is operating, the control will respond within 0.8 seconds. On re-cycle models, the gas valve is de-energized and a new interpurge and TFI sequence will begin. On optional re-ignition models, the gas valve will stay energized and the HV spark will be energized for a trial for ignition period to attempt to relight the burner. If the burner does not light the control will de-energize the gas valve. Multi-try models will make two more attempts to relight the burner. If the burner does not relight the control will go into lockout as noted above in "Failure to light". If flame is re-established, normal operation resumes.

## Combustion Airflow Problems

If the airflow signal is lost, or the hi-limit opens during heat mode, the gas valve is immediately de-energized and the blower stays on. If the switch closes again, a normal ignition sequence will resume. If not and this condition persists for more than five minutes, the control will enter lockout with the blower off.

## MOUNTING AND WIRING

The 35-53 is not position sensitive and can be mounted vertically or horizontally. The control may be mounted on any surface and fastened with #6 sheet metal screws. Secure the control in an area that will experience a minimum of vibration and remain below the maximum ambient temperature of 80°C (175°F).

All connections should be made with UL approved, 105°C rated, 18 gauge stranded wire with .054" minimum insulation thickness, .054" thick insulated wire. Refer to the appropriate wiring diagram when connecting the 35-53 to other components in the system. High voltage spark cables and control wiring harnesses are detailed on Page 3.

## EDGE CONNECT TERMINALS

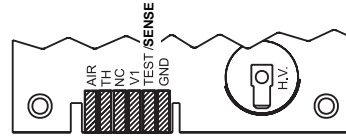

**WARNING:** The 35-53 uses voltages of shock hazard potential. Wiring and initial operation must be done by a qualified service technician.

## Terminal Designations

| TERMINAL   | DESCRIPTION    | TERMINAL TYPE        | LOC-ATION | WIRE COLOR |
|------------|----------------|----------------------|-----------|------------|
| PWR *      | + 12 VDC Power | 3/16" Q.C. Terminal  | -         | -          |
| BLO *      | Blower         | 1/4" Q.C. Terminal   | -         | -          |
| AIR *      | Airflow Switch | 6 Pin Edge Connector | 1         | Red        |
| TH *       | Thermostat     | 6 Pin Edge Connector | 2         | Orange     |
| NC         | NC Contact     | 6 Pin Edge Connector | 3         | Blue       |
| V1         | Gas Valve      | 6 Pin Edge Connector | 4         | Brown      |
| TEST/SENSE | Local Sense    | Unused               | 5         | -          |
|            | Remote Sense   | 6 Pin Edge Connector | 5         | Black      |
| GND        | Ground         | 6 Pin Edge Connector | 6         | Yellow     |

\* Air terminal provides +12 VDC power for models without blower control DWR, BLO and TH terminals are not used.



**CAUTION:** Label all wires prior to disconnection when servicing the control. Wiring errors can cause improper and dangerous operation. A functional checkout of a replacement is recommended.



**WARNING:** Operation outside specifications could result in failure of the Fenwal product and other equipment with injury or death to people and damage to property.

## TROUBLESHOOTING GUIDE

| SYMPTOM  | RECOMMENDED ACTIONS  |
|--|--|
| 1. Dead  | A. Miswired<br>B. Transformer/battery bad<br>C. Fuse/circuit breaker bad<br>D. No voltage @ PWR or AIR<br>E. Bad control |
| 2. Thermostat on - No blower output                                      | A. Miswired or failed air flow switch<br>B. Bad thermostat no voltage @ TH<br>C. Bad control                             |
| 3. Airflow Switch input okay but no trial for ignition after purge delay | A. Miswired<br>B. Bad control  |
| 4. Valve on, no spark  | A. Shorted electrode<br>B. Open HV cable<br>C. Miswired<br>D. Bad control  |
| 5. Spark on, no valve  | A. Valve coil open<br>B. Open valve wire<br>C. Bad control<br>(check voltage between V1 & GND)                           |
| 6. Flame okay during TFI, no flame sense (after TFI)                     | A. Bad electrode<br>B. Bad HV wire<br>C. Poor ground at burner<br>D. Bad control (check flame current)                   |

## CONTROL WIRE HARNESS

Select the proper harness based on the 35-53 control's termination connection. Once the terminal configuration is determined, complete the part number by replacing the last two digits ("XX") with the length in inches ("I" dimension). Standard wire lengths are 12, 18, 24, 30, 36 and 48 inches. Example 05-129927-024 = 24 inches. For other lengths, please contact Fenwal

### Local Sense Models

Part Number: 05-129927-0XX

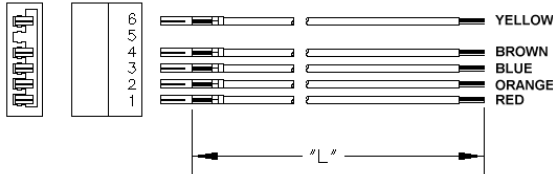

### Remote Sense Models

Part Number: 05-129927-2XX

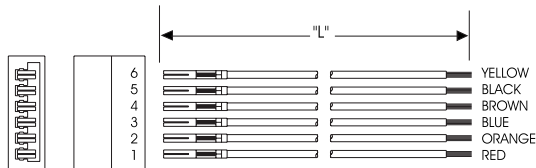

## ELECTRODE ASSEMBLIES

With over 1,000 configurations of spark electrodes and flame sense rods, Fenwal has a design for almost any application. The latest state-of-the-art wire forming and assembly equipment is used to accurately and efficiently produce high quality electrodes that deliver the hottest spark. The "Universal" electrodes depicted below are just a sampling of the 1,000 electrode styles available. These electrodes are designed for on-site customization. Cut and bend these to fit your application and then send the formed electrode back for Fenwal to detail *or* send us a print and will provide you with a quote and samples.

Part Number: 22-100001-117

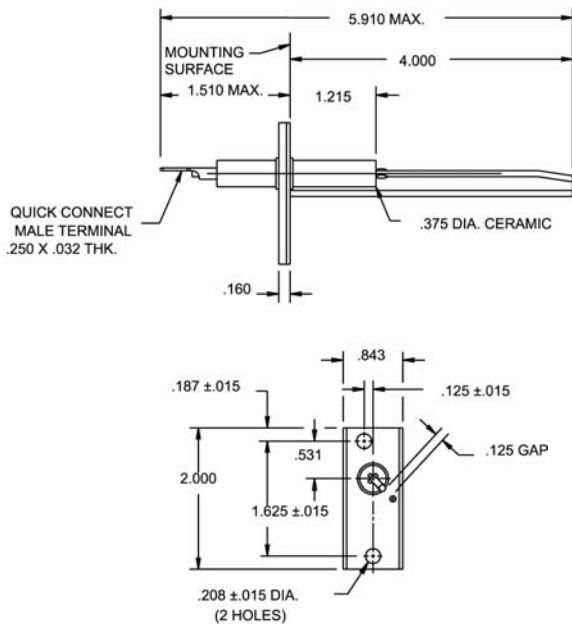

Part Number: 22-100001-052

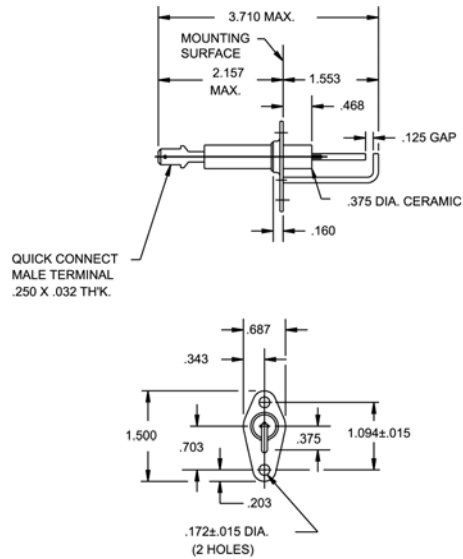

## REMOTE FLAME SENSE RODS

Part Number: 22-100001-080

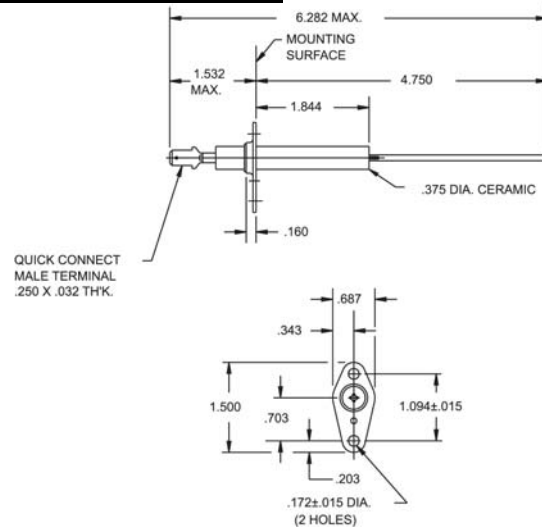

Part Number: 22-100001-110

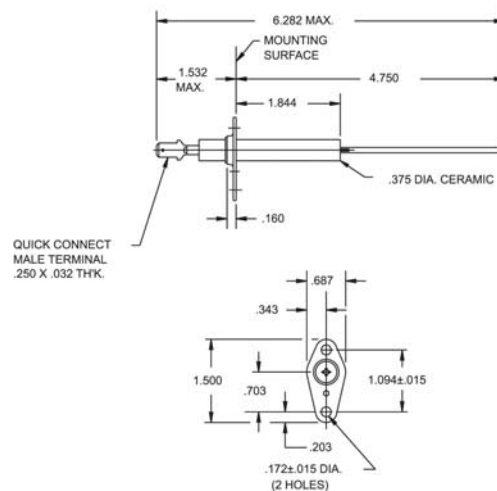

# WIRING DIAGRAMS

## LOCAL SENSE WITH BLOWER RELAY

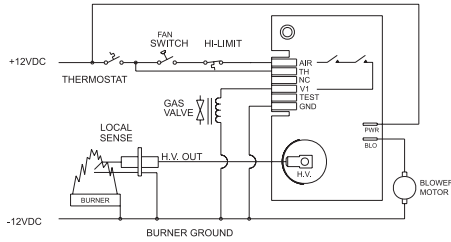

## LOCAL SENSE WITHOUT BLOWER RELAY

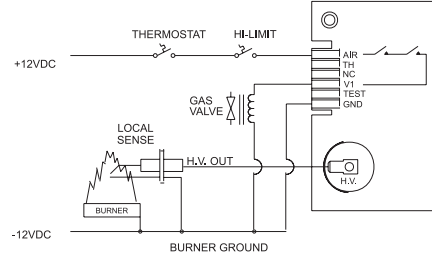

## REMOTE SENSE WITH BLOWER RELAY

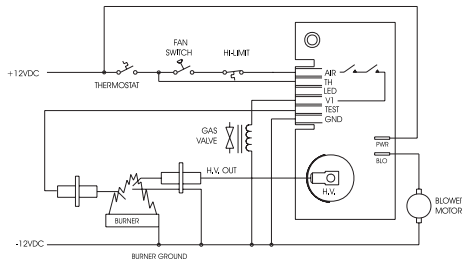

## REMOTE SENSE WITHOUT BLOWER RELAY

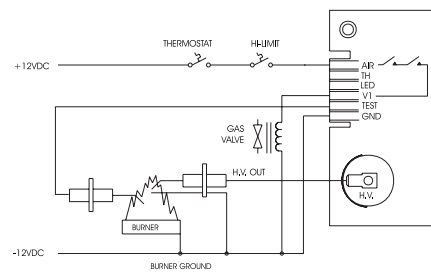

# DIMENSIONS

## CASE AND COVER

Figure 1:

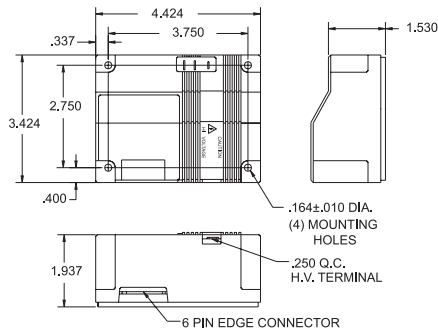

## INTEGRAL STAND-OFF

Figure 2:

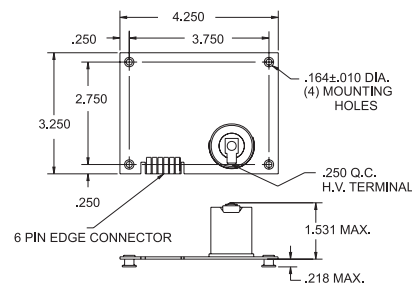

# CONTROL CONFIGURATION

**35 - 53 X**    **X X X**    **- X X X**

Blower Relay

0 = None

5 = Combustion Blower Relay

Configurations

5 = Standard Model, Recycle on Flame Loss

8 = Aftermarket Kit (may consist of control, high voltage ignition wire, electrode and harness)

9 = Non Standard Configuration

A 9 in this location of the part number (i.e. 35-53 5 901-113) identifies this configuration as a non-standard design. The part number does not follow the part numbering system. The 9XX is a sequential part number assigned by Fenwal. Consult factory for operating characteristics of this control.

## Description

Trial for Ignition Time (TFI)

1 = 5 seconds    3 = 7 seconds

5 = 10 seconds    7 = 25 seconds

Inter-Purge Time

0 = None    1 = 15 seconds

3 = 25 seconds

Pre-Purge Time

0 = None    3 = 25 seconds

1 = 15 seconds

Number of Ignition Trials and Flame Sense Method

0 = 1 try, local sense

1 = 1 try, remote sense

5 = 3 tries, local sense

6 = 3 tries, remote sense

Enclosure Configurations and Wiring Options

0 = Covered Module

5 = Integral Standoffs



400 MAIN STREET, ASHLAND, MA 01721  
TEL: (508) 881-2000 FAX: (508) 881-6729  
www.fenwalcontrols.com

© 2008 Kidde-Fenwal Printed in U.S.A. TAG

These instructions do not purport to cover all the details or variations in the equipment described, nor do they provide for every possible contingency to be met in connection with installation, operation and maintenance. All specifications are subject to change without notice. Should further information be desired or should particular problems arise which are not covered sufficiently for the purchaser's purposes, the matter should be referred to KIDDE-FENWAL, Inc., Ashland, Massachusetts.

P/N 35.53.02 3/21/05