

Valve monitoring system

VDK 200 A S02

8.01

DUNGS®



Technical description

The VDK 200 A S02 is the compact valve monitoring system for automatic shut-off valves:

- Device operates independent of inlet pressure
- Test volume ≤ 20 l
- Setting possible on site
- The complete test procedure is defined
- Release time: max. 26 s
- Tightness or leaks are displayed by an LED
- Suitable for TRD systems
- Electrical connection at screw terminals via PG 11 cable entry

Application

Valve proving system for DUNGS single valves MV.../5 and ZR.../5. Suitable

for all automatic shut-off valves as per EN 161 Class A, connection to G 1/4 thread.

Refer to Datasheet 8.02 for special version for H₂ applications.

Suitable for gases of families 1, 2, 3 and other neutral technical combustion gases.

Approvals

EU type test approval as per EU Gas Appliance Directive.

CE-0085 AQ 0808

Approvals in other important gas-consuming countries.

Special design for the North American market with U_L, FM and CSA registration.

Specifications

Operating pressure	max. 360 mbar (36 kPa)		
Test volume	≤ 20 l		
Pressure increase by motor pump	35 - 40 mbar		
Nominal voltage	230 V AC -15% to -240 V +6% For further voltages, refer to type overview		
Frequency	50 Hz (For 60 Hz, refer to type overview)		
Power requirements	During pumping time approx. 80 VA, in operation 20 VA		
Back-up fuse (provided by customer)	10 A fast-blow fuse or 6.3 A slow-blow fuse		
Fuse installed in housing cover, replaceable	Microfuse T 6.3 L 250 V; IEC-127-2/III (DIN 41 662)		
Switching current	Operating output	Terminal 13:	max. 4 A
	Interference output	Terminal 14:	max. 1 A
Degree of protection	IP 40		
Ambient temperature	-10 °C to +60 °C		
Release time	10 ... 26s, dependent on test volume		
Interference time	32 ± 3 s		
Sensitivity limit	50 l/h		
Switch-on duration of control	100 %		
Max. number of test cycles	15/h		
Installation position	upright to horizontal, not inverted		

For specifications of version for hydrogen, refer to Datasheet 8.02

Program flowchart

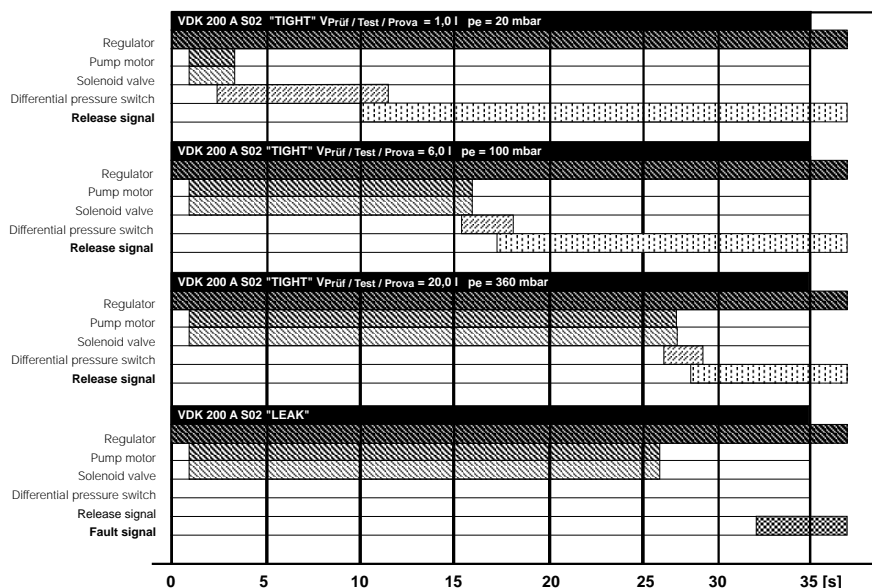

Functional description

The VDK 200 A S02 operates according to the pressure build-up principle.

The program module starts to function when heat is requested.

Test is performed depending on the burner functional procedure:

- Test **prior to** burner start or
- Test **during** pre-purge time or
- Test **after** burner shut-down

The VDK 200 S02 performs a self-test during a switching sequence.

Function principle

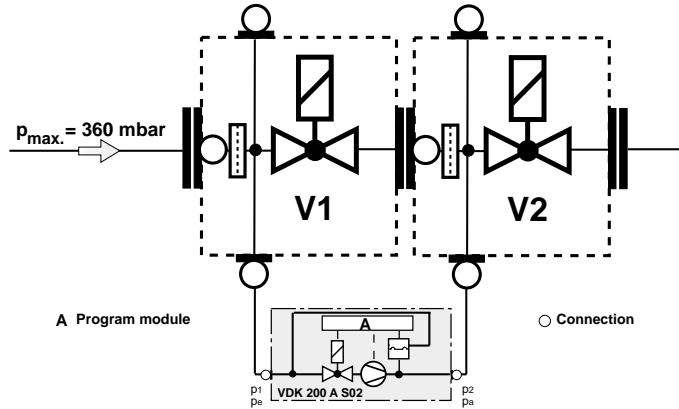

Program flowchart

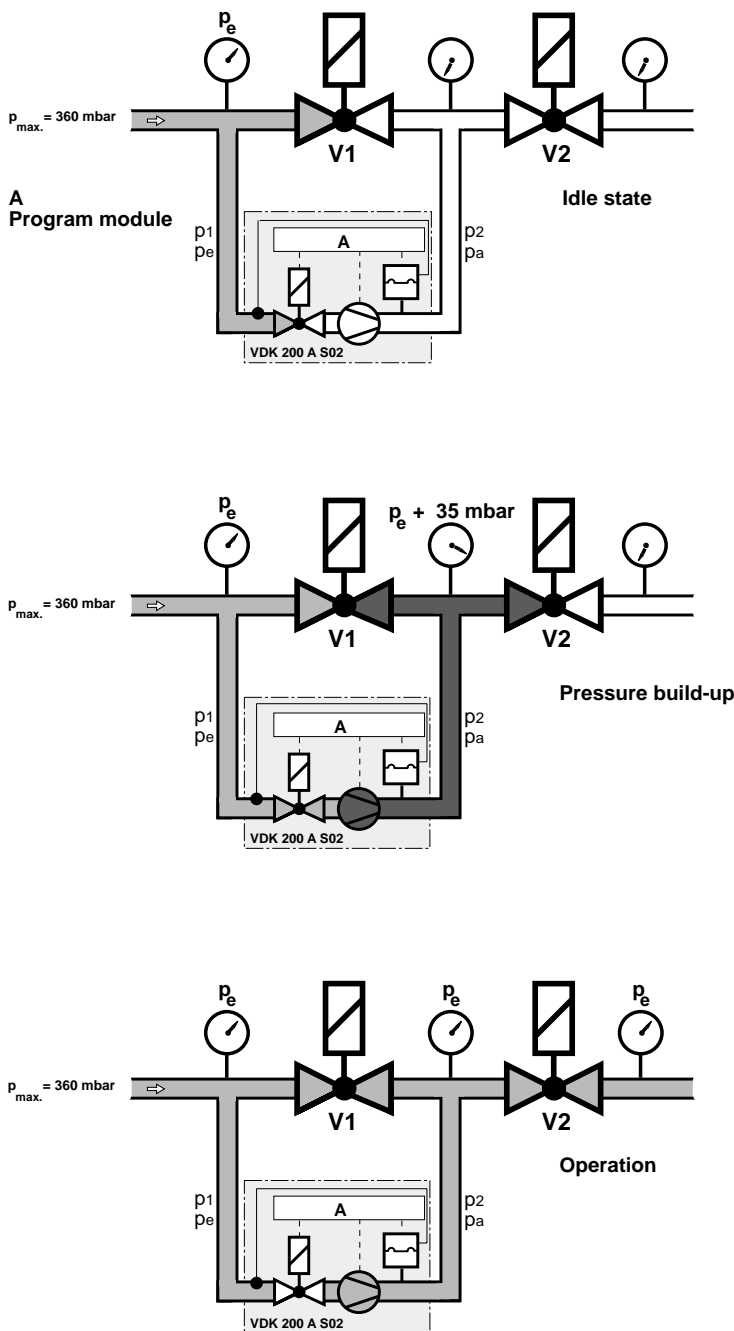

Idle state:

Valve V1 and valve V2 are closed.

Pressure build-up:

The internal motor pump increases the gas pressure p_e in the test section by about 35mbar compared with the pressure arising on the inlet side at valve V1.

During the test period (pump period) the integrated differential pressure switch monitors the test section for leaks. When the test pressure is reached, the motor pump switches off (end of test period), and the yellow LED flashes until the contact is released. The release time (max. 26s) is dependent on test volume (max. 20l) and inlet pressure (max. 360mbar).

If the test section is leak-tight, the contact is released to the automatic burner control after 26s and the yellow LED comes on.

If the test section is leaky or if the pressure rise by +35 mbar is not reached during the test period (max. 26 s), the VDK 200 A S02 switches to fault. The red signal lamp lights as long as the contact is released by the regulator or thermostat (heat request).

An automatic restart is performed on short-term voltage failure during the test or in burner mode.

Operation:

Valve V1 and valve V2 are open, the internal valve of VDK 200 A S02 is closed.

Dimensions [mm]

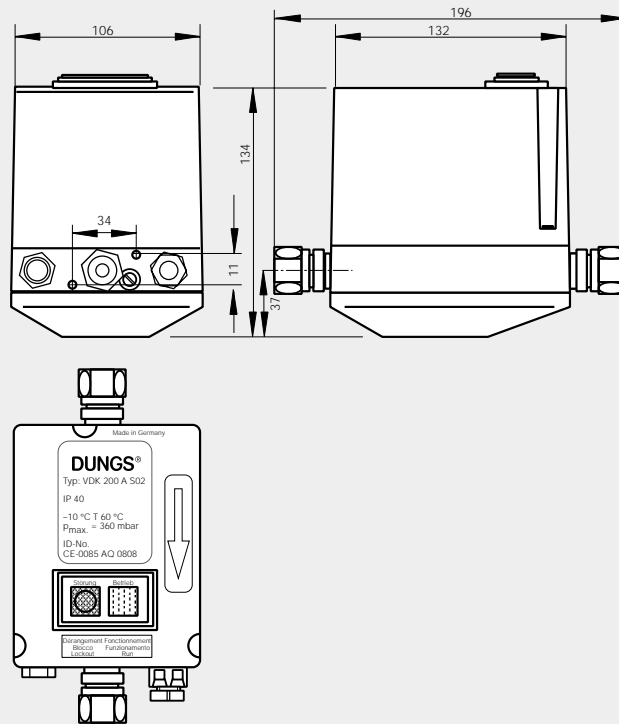

Electrical connection

VDK 200 A S02

Connection to screw terminals via PG* 11 cable gland (* = heavy-gauge conduit thread).

! Only use terminals 1, 3, 13 and 14. If you do not observe this instruction, it may result in personal injury or material damage.

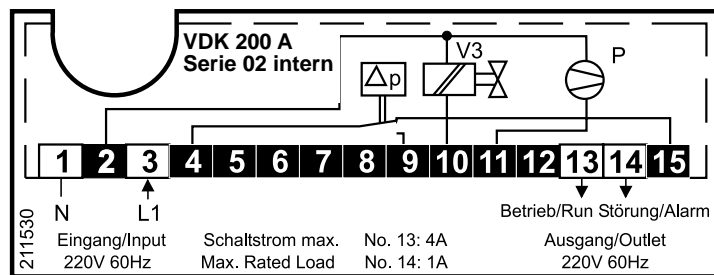

Startup

Check test section for leaks after assembly.

Start test by using temperature regulator and/or restart or by pressing the reset button on VDK 200 A S02.

If the test section is tight

Depending on the length of the test section and the residual pressure applied, the pumping time can be up to 26 s.

The release for the automatic burner control is then given after approx. 30 s at the earliest - the yellow LED lights up permanently.

If the test section is leaky

The test pressure is not reached. The motor pump switches off, the red fault lamp lights up. Switch-through to the automatic burner control does not take place.

Functional check

By opening a screw plug p_2 (p_a) during the test period (pumping time), leakage can be simulated and a function check can take place.

Setting

The VDK 200 A S02 is preset at the factory. Setting the VDK 200 A S02 is possible on site. Setting is performed at the externally accessible setting screw. Apply varnish to the setting screw after startup. Keep strictly to the instructions.

Assembly

Connect the VDK 200 A S02 using two steel tubes (12 mm dia.) on the side of the DUNGS single valves (mounting is possible either on the right or the left).

! If an exhaust gas valve is installed in the boiler, it must be open at the beginning of the test.

! In order to prevent functional and leakage problems, we recommend the use of solenoid valves as per EN 161 Class A, Group 2.

! The connection lines between VDK 200 A S02 and the valves must withstand mechanical, chemical and thermal loads.

Using the VDK 200 A S02 at DUNGS individual solenoid valves .../5

We recommend the use of the connection kit, Order No. 137 710, for mounting the VDK 200 A S02 on the valves Rp 1 1/2 to Rp 2 and or/ DN 40 to DN 50.

We recommend the use of the connection kit, Order No. 137 550, for mounting the VDK 200 A S02 on the valves DN 65 to DN 150.

Determining test volume V_{Test}

Determine outlet-side volume of V1. Refer to table for Rp 3/8 to DN 200.
 Determine inlet-side volume of V2. Refer to table for Rp 3/8 to DN 200.
 Determine volume of intermediate pipeline section 3. Refer to table for Rp 3/8 to DN 200.

$$V_{Test} = \text{Volume}_{\text{Valve 1}} + \text{Volume}_{\text{Intermediate pipeline section}} + \text{Volume}_{\text{Valve 2}}$$

⚠ The max. test volume of 20 l must not be exceeded.

$$V_{Test} = \text{Valve volume (V1 outlet + V2 inlet)} + \text{Volume of pipeline}$$

Determining test volume V_{Test}

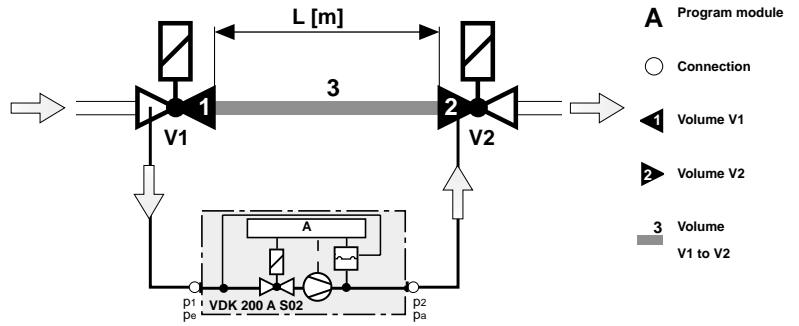

Rp / DN	Valve- Volume [l]		Test volume [l] = Volume V1 _{outlet} + V2 _{inlet} + Pipeline length							
	V1 _{outlet}	V2 _{inlet}	0,5 m		1,0 m		1,5 m		2,0 m	
	Rp	DN	Rp	DN	Rp	DN	Rp	DN	Rp	DN
Rp 3/8	0,01 l		0,06 l		0,11 l		0,16 l		0,21 l	
Rp 1/2	0,07 l		0,17 l		0,27 l		0,37 l		0,47 l	
Rp 3/4 (DN 20)	0,12 l		0,27 l		0,42 l		0,57 l		0,72 l	
Rp 1 (DN 25)	0,20 l		0,45 l		0,70 l		0,95 l		1,20 l	
Rp 1 1/2 / DN 40	0,50 l	0,70 l	1,20 l	1,40 l	1,80 l	2,0 l	2,45 l	2,7 l	3,10 l	3,3 l
Rp 2 / DN 50	0,90 l	1,20 l	1,90 l	2,2 l	2,90 l	3,2 l	3,9	4,2 l	4,90 l	5,5 l
DN 65	1,30 l	2,0 l		3,7 l		5,3 l		7,0 l		8,6 l
DN 80		3,8 l		6,3 l		8,8 l		11,3 l		13,8 l
DN 100		6,5 l		10,5 l		14,4 l		18,4 l		22,3 l
DN 125		12,5 l		18,7 l		24,8 l		31,0 l		37,1 l
DN 150		17,5 l		26,5 l		35,2 l		44,1 l		52,9 l
DN 200		46,0 l		61,7 l		77,4 l		93,1 l		108,8 l

For systems with test volume $V_{Test} \leq 4$ l, we recommend the use of valve proving system VPS 504 S (refer to Datasheet 8.05).

VDK 200 A S02 type overview / accessories / order details

Version		Order No.
VDK 200 A S02	230 VAC 50 Hz	211 222
VDK 200 A S02	110 VAC 50 Hz	211 224
VDK 200 A S02	220 VAC 60 Hz	211 225
VDK 200 A S02	240 VAC 50 Hz	211 229
VDK 200 A S02	120 VAC 60 Hz	211 927

Hydrogen version

VDK 200 A S02 H ₂ -version	230 VAC 50 Hz	214 445
VDK 200 A S02 H ₂ -version	220 VAC 60 Hz	222 166
VDK 200 A S02 H ₂ -version	120 VAC 60 Hz	222 747

For specifications, refer to Datasheet 8.02

Accessories / spare parts

Cable gland with strain relief		231 778
Connection kit	Rp 1 1/2 - Rp 2, DN 40 - DN 50	137 710
Connection kit	DN 65 - DN 150	137 550
Equipment fuse element		231 780

We reserve the right to make any changes in the interest of technical progress.



Head Offices and Factory
Karl Dungs GmbH & Co.
 Siemensstraße 6-10
 D-73660 Urbach, Germany
 Telephone +49 (0)7181-804-0
 Fax +49 (0)7181-804-166

Postal address
Karl Dungs GmbH & Co.
 Postfach 12 29
 D-73602 Schorndorf, Germany
 e-mail info@dungs.com
 Internet www.dungs.com