

DESCRIPTION

The VSR 0251 series Slam Shut Valves (SSV) with shut-off device RI.ORG.0251 are designed to protect gas networks from low and medium pressures.

They are usually installed at the inlet part of the line, and can protect against over-pressure (OPSO), lack of pressure (UPSO) or both (OPSO/UPSO).

The SSV has two main parts: the shut-off device (1) and the body (2), which is connected to the gas pipe line.

The shut-off device can be installed to an independent body to form the slam shut valve; or to the body of a regulator in which will be known as a regulator with OPSO/UPSO valve.

MODELS

There are three models in the range, depending on the required OPSO/UPSO pressures:

Model BP (VSR 0251, this technical data sheet)

Under-pressures shut-off (UPSO) from 10 to 115 mbar

Over-pressures shut-off (OPSO) from 40 to 240 mbar

Model MP (please refer to technical data sheet VSR 0252)

Under-pressures shut-off (UPSO) from 35 to 400 mbar

Over-pressures shut-off (OPSO) from 180 to 800 mbar

Model AP (please refer to technical data sheet VSR 0253)

Under-pressures shut-off (UPSO) from 150 to 2500 mbar

Over-pressures shut-off (OPSO) from 500 to 4000 mbar

ASSEMBLY

- Prior to installing the SSV, please verify the pressure and connection details required corresponds with the information on the label.
- Assure that the fluid flows in the direction that the arrow (14) indicates.
- Make the connection of the sense lines (4) to a straight pipeline, turbulence free, downstream the outlet (at a distance of at least 5 times the diameter of the pipe). The sense line tube should have a minimum diameter of 10mm and should be totally exempted of any type of obstruction, valves and diameter reductions.
- The location of the SSV at the installation should be adequate to allow maintenance labors and pressure adjustments.
- The shut-off valve can be rotated 360° by loosening the four screws (5) with a hexagonal 2.5 mm wrench. Through this adjustment, the 1/4" x Ø10 (4) adaptor can be controlled.

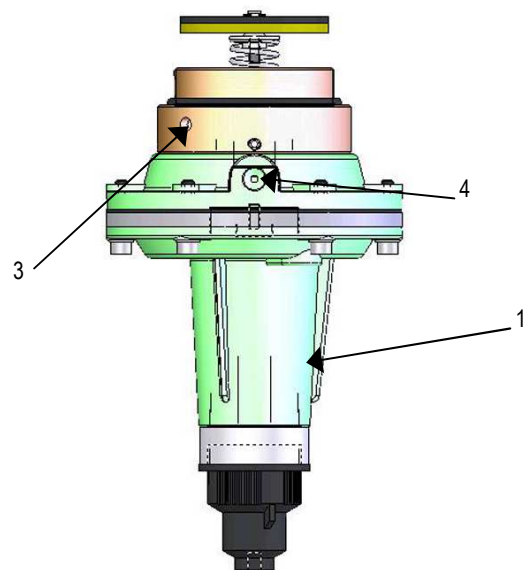
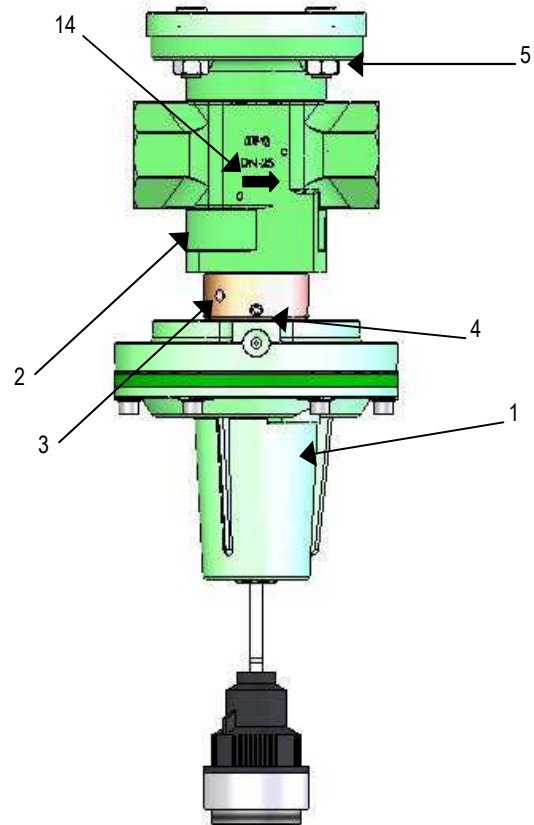

SHUT-OFF DEVICE

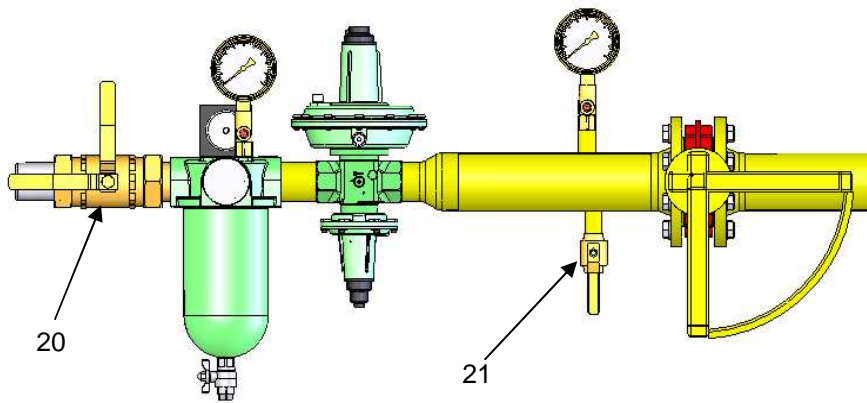

STARTUP PROCEDURE

- Cause a slight flow of gas downstream from the SSV. For example, using a bleed valve (21).
- Slightly and slowly open the inlet valve (20), located upstream of the SSV.
- Extract the plastic cap (6) located on the top of the shut-off device (1).
- Invert the cap (6) and screw it at the end of the unblocking axis (7).
- Gently pull the cap (6) to open the internal bypass of the seat disc and slowly pressurize outlet pipeline connected to SSV exit.
- When the outlet pressure has stabilized, finish by pulling the cap (6) firmly until the internal mechanism locks.
- Unscrew the cap (6) of the unblocking axis (7) and, invert it again to fit it to the head of the shut-off valve and to protect the element.

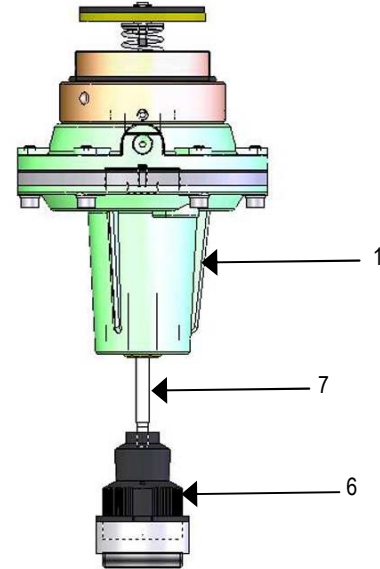

REGULATOR SETUP

Over pressure shut-off (OPSO)

The two main elements used to set the over pressure shut-off are the screwed ring (9) and the OPSO spring (10). To increase the shut-off point, use a 22mm hexagonal tube spanner and turn the screwed ring (9) clockwise. Turning it in the opposite direction reduces the over pressure shut-off point.

The adjustment spring (10) has a defined range of pressures, so when the over pressure shut-off varies significantly the spring should be changed (see springs table).

Under pressure shut-off (UPS0)

The screwed cap (11) and the UPSO spring (12), are the elements used to set the under pressure shut-off. To reduce the shut-off point to its minimum level, use a 16mm hexagonal tube spanner to turn the bolt (11) anti-clockwise. Turning it in the opposite direction rises the under pressure shut-off point.

The adjustment spring (12) has a defined range of pressures, so when the under pressure shut-off varies significantly the spring should be changed (see springs table).

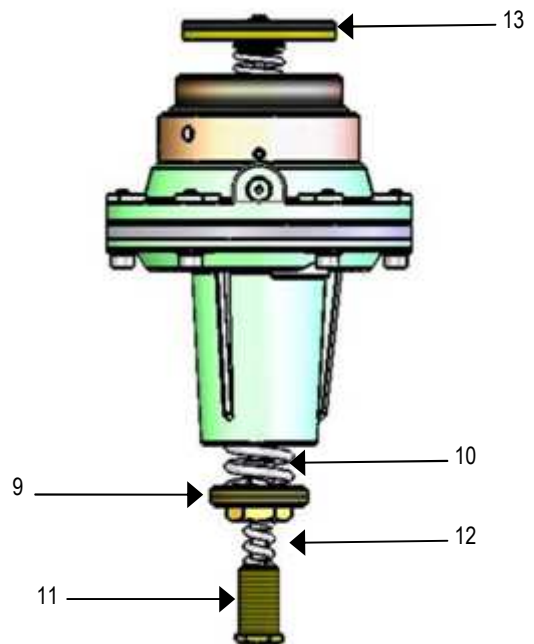

Causes of abnormal operation:

- Sense lines not connected, blocked or leaking.
- Sense lines may be of insufficient diameter, or connected at a location of turbulence in the pipeline.
- Shut-off pressure required is outside the range of the spring installed.
- Shut-off pressure too similar to the associated regulator outlet pressure.

If the Slam Shut Valve does not close properly:

- A worn, damaged, filth, or pitted Valve Seat Disc (13)
- Orifice may be worn.
- O-ring may be worn.

CANCELLING THE OPSO

Substitute the OPSO spring (10) with a firm tube that immobilizes the internal plastic cone or substitute the current spring with another of greater value such that performing a maximum block would not make sense.

CANCELLING THE UPSO

Remove the cap (6) and the bolt (11). Extract the UPSO spring (12) and re-assembly the bolt (11) and the cap (6).

REPLACING THE SHUT-OFF DEVICE







Removing the shut-off device:

- Using the 19mm spanner, disconnect the sense line (4).
- Using the appropriate hook spanner, inserted into the opening (3), unscrew the shut-off device half turn.
- Finish extracting the shut-off device from the valve body, turning it anticlockwise.

Re-assembling

- Screw the shut-off device to the valve body, turning it clockwise.
- Using the appropriate hook spanner, inserted into the opening (3), tighten the shut-off device to the valve body.
- Loosen the four internal screwed bolts using a hexagonal 2.5mm wrench.
- Rotate the shut-off valve until the joint lines up with the pressure tube.
- Tighten the four internal screwed bolts using the hexagonal 2.5mm wrench.

TOOLS REQUIRED FOR THE MAINTAINANCE OF THE VSR 0251 SHUT-OFF VALVE

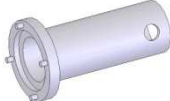
			
Hook-Spanner 60-90	O-Ring extractor	Allen key 2.5 - 4 - 8	Tube Spanner 16 - 22
			
Open-end Spanner 7 - 17 - 19	Screwdriver 10 x 1.6	Tweezers	Orifice key ZM.1.00.3335

UPSO ADJUSTMENT SPRINGS

Spring code	Spring color	Ø Wire (mm)	Length (mm)	Ø Outside (mm)	Spring Range in kPa (mbar)
ZM.3.10.060.121	White	1.2	60	10	1.0 ÷ 3.2 (10 ÷ 32)
ZM.3.13.055.151	Yellow	1.5	55	13	2.4 ÷ 3.7 (24 ÷ 40)
ZM.3.13.055.201	Blue	2.0	55	13	3.0 ÷ 11.5 (30 ÷ 115)



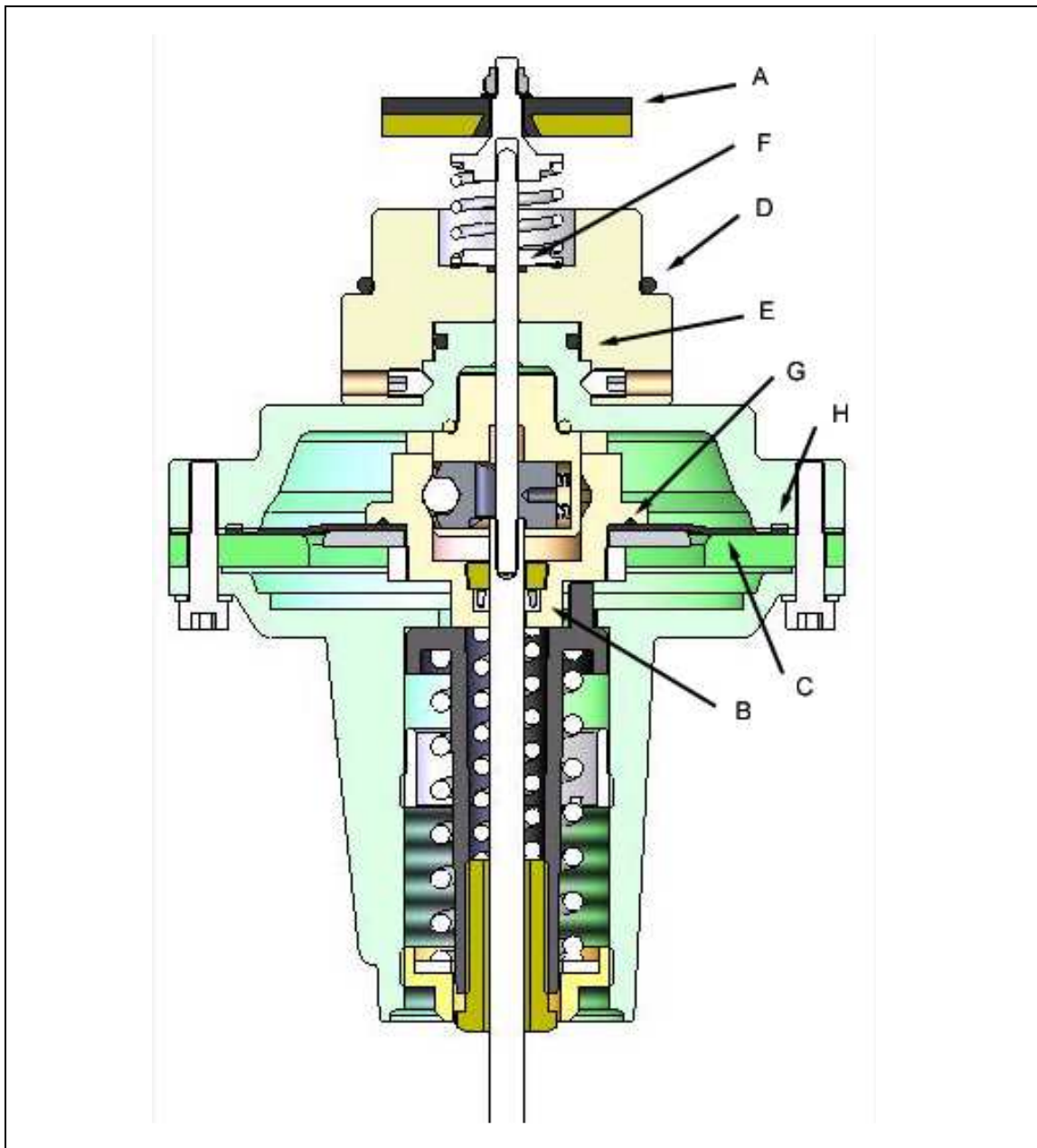

OPSO ADJUSTMENT SPRINGS

Spring code	Spring color	Ø Wire (mm)	Length (mm)	Ø Outside (mm)	Spring Range in kPa (mbar)
ZM.3.30.060.221	Silver	2.2	60	30	4.0 ÷ 13.0 (40 ÷ 130)
ZM.3.30.060.251	Green	2.5	60	30	6.0 ÷ 19.0 (60 ÷ 190)
ZM.3.30.060.271	Red	2.7	60	30	9.0 ÷ 24.0 (90 ÷ 240)

WARNING! It is potentially dangerous to manipulate a gas installation and its components. Therefore all start-up, adjustments and maintenance of the regulator must be carried out by duly authorized people with sufficient technical knowledge.

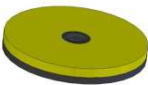

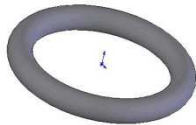
SPARE PARTS FOR VSR 0251

 <p>Seat disc (A) Code ZM.1.00.0552A</p>	 <p>Orifice Code ZM.1.00.0543</p>	 <p>"O" rings in the triggering device</p> <table border="1"> <thead> <tr> <th>Item</th> <th>Dimensions</th> <th>Code</th> </tr> </thead> <tbody> <tr> <td>D</td> <td>31.00 x 37.00 x 3.00</td> <td>ZM.1.00.1467</td> </tr> <tr> <td>E</td> <td>21.00 x 26.00 x 2.50</td> <td>ZM.1.00.1318</td> </tr> <tr> <td>F</td> <td>3.00 x 6.50 x 1.75</td> <td>ZM.1.00.1224</td> </tr> <tr> <td>G</td> <td>24.00 x 29.00 x 2.50</td> <td>ZM.1.00.0208</td> </tr> </tbody> </table>	Item	Dimensions	Code	D	31.00 x 37.00 x 3.00	ZM.1.00.1467	E	21.00 x 26.00 x 2.50	ZM.1.00.1318	F	3.00 x 6.50 x 1.75	ZM.1.00.1224	G	24.00 x 29.00 x 2.50	ZM.1.00.0208
Item	Dimensions	Code															
D	31.00 x 37.00 x 3.00	ZM.1.00.1467															
E	21.00 x 26.00 x 2.50	ZM.1.00.1318															
F	3.00 x 6.50 x 1.75	ZM.1.00.1224															
G	24.00 x 29.00 x 2.50	ZM.1.00.0208															
 <p>Retainer (B) Code ZM.1.00.0353</p>	 <p>Main diaphragm (C) Code ZM.1.00.00131</p>	<p>"O" rings in the valve body</p> <table border="1"> <tbody> <tr> <td>J</td> <td>60.20 x 66.20 x 3.00</td> <td>ZM.1.00.0509</td> </tr> <tr> <td>K</td> <td>28.25 x 33.49 x 2.62</td> <td>ZM.1.00.1346</td> </tr> </tbody> </table>	J	60.20 x 66.20 x 3.00	ZM.1.00.0509	K	28.25 x 33.49 x 2.62	ZM.1.00.1346									
J	60.20 x 66.20 x 3.00	ZM.1.00.0509															
K	28.25 x 33.49 x 2.62	ZM.1.00.1346															