

### DESCRIPTION

VS-25 relief valves are for protecting gas networks against excessive pressure of between 30 and 100 mbar.

They allow the discharge of an amount of gas into the atmosphere when incoming pressure rises and exceeds a certain pre-set value, generally as a result of:

- Effect of the temperature in the pipeline (with no flow).
- Excessively fast closing of the cut-off valve or electro valve, causing hammering.
- Incorrect closing of the regulator or a cut-off valve mounted upstream.

They consist of the threaded head adjustment (1) and the body (2), which is connected to the gas pipeline.

### MODELS

There are three models in the range, depending on the required outlet pressures.

Model BP (Low pressure version): For outlet pressures from 3 to 10 kPa (30 to 100 mbar).

Model MP (Medium pressure version): For outlet pressures from 7 to 25 kPa (70 to 250 mbar). (This technical sheet).

Model AP (High pressure version): For outlet pressures from 19 to 55 kPa (190 to 550 mbar).

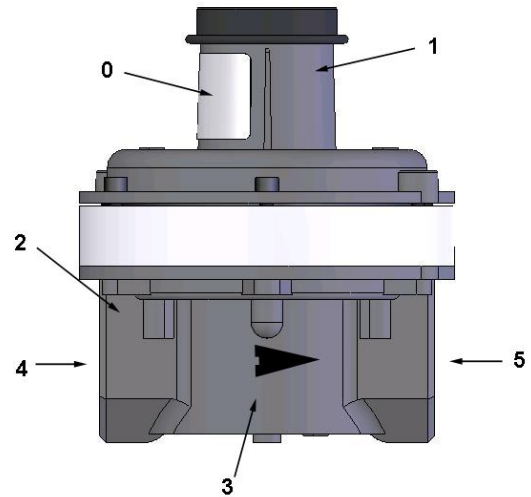

### CONNECTIONS

Screwed connections (4 and 5) are 1" G male and may be supplied with flanged DN-25 PN-16 connections, by mounting APQ lap joint flanges.

### SET UP

- Before installing, you should check that the features shown on the relief valve label (0) correspond with those required for the installation to be protected.
- Check that the fluid passes through the body of the relief valve in the correct direction, following the direction of the arrow (3) marked on the body of the relief valve (2). You should connect the gas pipeline to be protected to the 1" male connection point (4).
- Connect the atmosphere-discharge pipeline to the 1" male connection point (5). This pipeline must be at least 1". An inverted u-bend must be fitted at the opposite end (upper part) of the pipe or alternatively the pipe must be bent 180° to avoid rainwater from getting in.
- Both the tube that connects from the relief valve gas pipeline and the tube that connects the relief valve to the atmosphere must be totally free from shut-off valves which could obstruct the passage of gas.
- The relief valve must be positioned to allow sufficient room for maintenance and adjustment work.
- Where a different pressure level is required from the one requested initially, the spring (7) must be changed for the correct type, selecting from the tables of springs given below.
- It is good practice to mount a PUSH valve at the input to the relief valve; this enables the VS-25 to be checked and adjusted without having to bring the installation to a halt.

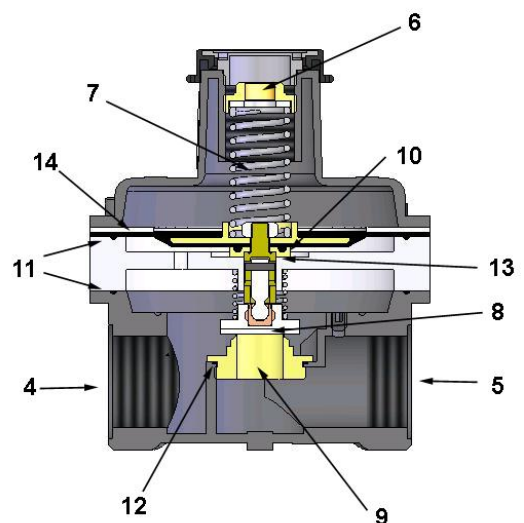

### NO-PUSH STARTING

- Using a 14mm socket wrench, tighten the adjustment nut (6) to 80% of its length.
- Increase the pressure in the VS-25 inlet pipeline until the desired operating value is reached. This can be done using by-pass or by increasing the pressure within the regulator.
- Using a 14mm socket wrench, slowly loosen the adjustment nut (6) until the VS-25 starts to open.

Again, increase the pressure in the gas piping and ensure that the VS-25 opens, limiting the pressure at the desired point. If there is a mismatch, readjust the calibration of the VS-25 slightly

### PUSH STARTING

- Using a 14mm socket wrench, tighten the adjustment nut (6) to 80% of its length.
- Apply an external pressure source to the ¼" G auxiliary input of the PUSH valve.
- Holding back the red PUSH lever, use the 14 mm socket wrench to slowly loosen the adjustment nut (6) until the VS-25 starts to open.
- Again, increase the pressure at the PUSH auxiliary input and check that the valve opens, limiting the pressure at the desired point. If there is a mismatch, readjust the calibration of the VS-25 slightly.

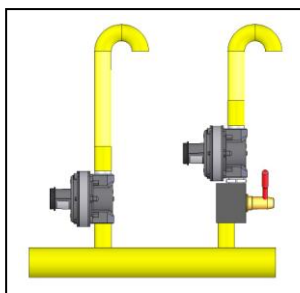

Example of assembled VS-25 with and without PUSH



### MAINTENANCE TOOLS

			
O-ring Extractor	Tweezers	Allen wrench 4	Hexagonal drive socket 6 - 14

### Spring Range in kPa (mbar) SPRING ADJUSTMENTS VS-25

Code spring	Spring colour	Ø E	L	Ø h	Spring Range in kPa (mbar)
ZM.3.20.060101A	Nickel + green strip	20	60	1.0	3.1 to 3.5 (31 to 35)
ZM.3.20.060111A	Nickel + red strip	20	60	1.1	3.5 to 4 (35 to 40)
ZM.3.20.060121A	Nickel + white strip	20	60	1.2	3.7 to 4.6 (37 to 46)
ZM.3.20.060131A	Nickel + yellow strip	20	60	1.3	4.3 to 5.5 (43 to 55)
ZM.3.20.060141A	Nickel + blue strip	20	60	1.4	5.2 to 6.5 (52 to 65)
ZM.3.20.060151A	Nickel + black strip	20	60	1.5	5.5 to 7.8 (55 to 78)
ZM.3.20.060161A	Nickel + violet strip	20	60	1.6	7.3 to 10.3 (73 to 103)

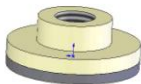
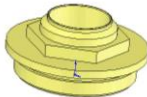
### SPARE PARTS FOR VS-25

			
Seat Disc (8) Code ZM.1.00.070618	Orifice (9) Code ZM1.00.0213	Construction O-rings (10) Code ZM.1.00.0284 (11) Code ZM.1.00.0599 (12) Code ZM.1.00.0026 (13) Code ZM.1.00.1283	Diaphragm (14) Code ZM.1.00.00132

VS 25 BP.doc