

### DESCRIPTION

The Sutton 4000□3 Regulator is designed for use in distribution networks with medium to high inlet pressures.

They are direct acting regulator, where the spring housing/regulator head (1) is mounted directly to the flanged body (2).

The Sutton 4010□3 versions include an optional Over-Pressure (OPSO) and/or Under-Pressure (UPS) Shut-Off facility, which takes the place of the lower body plug (3).

### MODEL

There are three models in the range, depending on the required inlet/outlet pressures.

Model BP (Low pressure version): For outlet pressures from 2 to 10 kPa (20 to 100 mbar).  
(Please refer to technical datasheet Sutton 4000□1)

Model MP (Medium pressure version): For outlet pressures from 8 to 35 kPa (80 to 350 mbar).  
(This technical sheet)

Model AP (High pressure version): For outlet pressures from 30 to 400 kPa (300 to 4000 mbar).  
(Please refer to technical datasheet Sutton 4000□5)

### CONNECTIONS

Model SUTON 4000 A3 is with 1.½" ANSI-150 flanges  
Model SUTON 4000 D3 is with DN-40 PN-25 flanges

### ASSEMBLY

- Prior to installing the regulator, please verify the pressure and connection details required correspond with the information on the label (15).
- Assure that the fluid flows in the direction that the arrow (14) indicates.
- Make the connection of the sense lines (12) to a straight pipeline, turbulence free, downstream the outlet of the regulator (at a distance of at least 5 times the diameter of the pipe). The sense line tube should have a minimum diameter of 10mm and should be totally exempted of any type of obstruction, valves and diameter reductions.
- The area of installation of the regulator should be adequate to allow maintenance labors and outlet pressure adjustments.
- The OPSO/UPS Device (Optional) is mounted on the lower section of the regulator. It monitors the downstream pressure independently of the main section of the regulator. The OPSO/UPS device can be ordered with the regulator, or can be fitted separately, later if required.

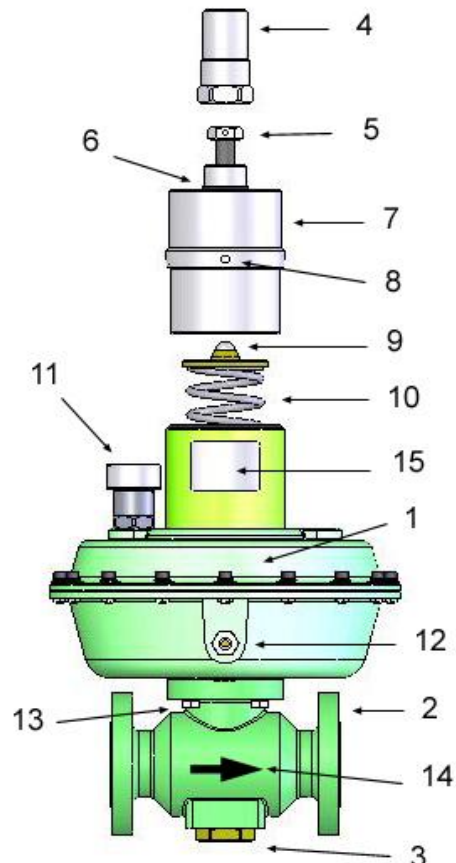
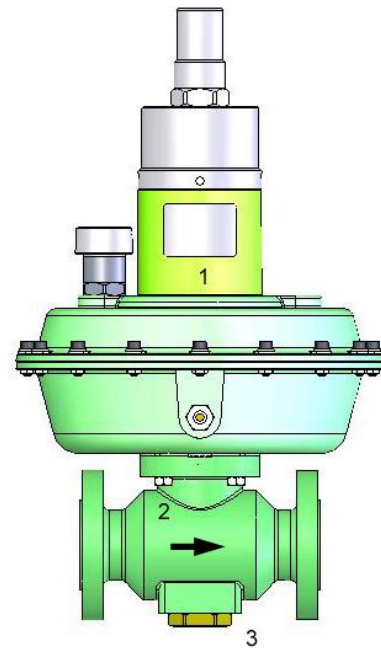

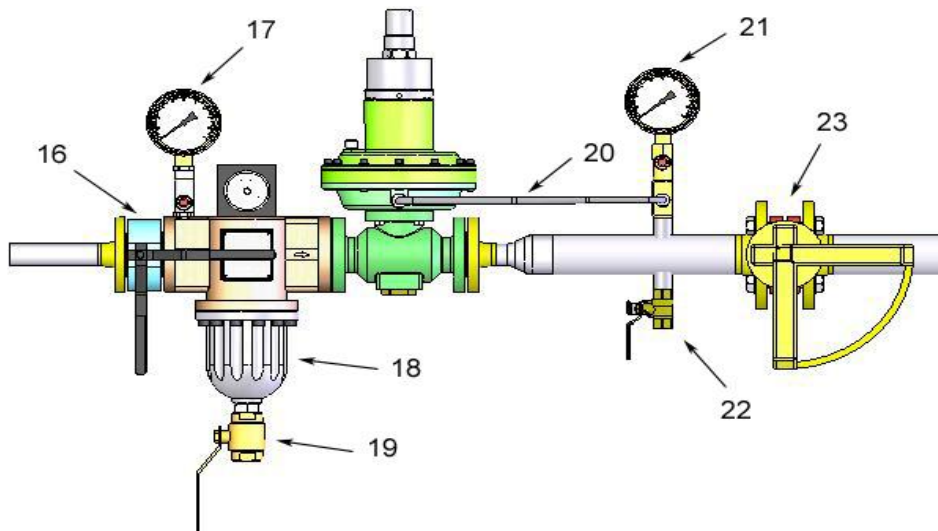

## STARTUP PROCEDURE

- Open the bleed valve (22) to provide a slight flow of gas.
- Slightly and slowly, open the inlet valve (16), located immediately upstream of the regulator.
- Check that the inlet pressure (17) is correct.
- Verify that the outlet pressure (21) has stabilized.
- The main inlet valve (16), found at the inlet of the filter (18), can now be fully opened.
- Slowly open the outlet valve (23).
- If the regulator is fitted with an OPSO/UPSO, this should be kept in mind.

## REGULATOR SETUP

Outlet Pressure Adjustment:

- Remove aluminum cap (4), located on the top of the regulator.
- To increase outlet pressure, turn the main spring adjustment bolt (5) CLOCKWISE with a Tube Spanner 24mm.
- Turning this bolt anti-clockwise will decrease the outlet pressure.
- Place aluminum cap (4) back onto the regulator top, make sure to put the O-ring (6).

The spring used in these regulators have been designed to provide specific outlet pressure ranges. For outlet pressures outside the specified range, a spring change will be required.

Causes of abnormal operation:

- Sense lines (20) not connected, blocked or leaking.
- Sense lines (20) may be of insufficient diameter, or connected at a location of turbulence in the pipeline.
- Pressure required is outside the range of the spring installed.
- Flow capacity requires exceeds regulator capacity.
- Atmospheric Vent (11) blocked or restricted.

If regulator does not close perfectly, this may be caused by:

- A worn, damaged, or pitted Valve Seat Disc.
- Orifice may be worn.
- O-ring may be worn.
- Deterioration of the main or compensation diaphragms.

If the OPSO/UPSO does not close perfectly:

- Please refer to the Technical Data Sheet relevant to the OPSO/UPSO device concerned.

To avoid particle damage of the internal working parts of the regulator, it is necessary to install a filter (18) of not less than 5 microns prior to the regulator.

## CHANGING THE MAIN SPRING:

Removing the main spring:

- Close inlet valve (16) and the outlet valve (23).
- Depressurize the inlet and outlet side of the regulator via purge valves 19 and 22.
- Remove main regulator cap (4) to access the bolt (5).
- Wind the adjustment bolt (5) ANTI-CLOCKWISE, until all pressures is taken off the main spring.
- Using a 90 to 155mm hook-spanner, turn the main spring housing (7) anti-clockwise to reveal the main spring.
- Extract the spring.

Re-assembly:

- Insert the spring of appropriate outlet pressure range.
- Re-assemble the main spring housing in reverse order to the above instructions.
- **Please ensure only spring of appropriate size are fitted, and the spring plate and ball-bearing are relocated on the top of the replacement spring, as failure to do so may cause regulator damage or failure.**



## REMOVAL OF THE MOBILE DEVICE:

- Close inlet Valve (16) and outlet Valve (23).
- Depressurize the inlet and outlet side of the regulator via purge valves 19 and 22.
- Disconnect the sense line connected to the underside of the main diaphragm housing (12).
- Using a 13mm spanner, loosen and remove the four body bolts (13).
- The regulator head can now be safely removed.

Re-assembly

- To re-fit the regulator head, reverse the above procedure.

### TOOLS REQUIRED FOR THE MAINTAINANCE OF THE SUTON 4000□3 REGULATORS

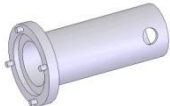
 Hook-Spanner 90-155mm	 O-ring Extractor	 Allen Key 4 - 5 mm	 Tube Spanner 13 - 24 mm
 Open-end Spanner 13 - 19 - 27 mm	 Screwdriver 10 x 1,6 mm	 Tweezers	 Orifice Key

### OUTLET PRESSURE ADJUSTMENT SPRINGS FOR THE SUTON 4000□3 REGULATORS

Spring Code	Spring Color	Ø Wire (mm)	Length (mm)	Ø Outside (mm)	n° Turns	Spring Range in kPa (mbar)
ZM370155070A	Nickel + Yellow Stripe	7	155	70	9.5	8 ÷ 16 (80 ÷ 160)
ZM370155080A	Nickel + Blue Stripe	8	155	70	9.5	10 ÷ 25 (100 ÷ 250)
ZM370155090A	Nickel + Black Stripe	9	155	70	9.5	15 ÷ 40 (150 ÷ 400)
ZM370155100A	Nickel + Purple Stripe	10	155	70	9.5	24 ÷ 65 (240 ÷ 650)
ZM370155110A	Nickel+ Orange Stripe	11	155	70	9.5	40 ÷ 100 (400 ÷ 1000)
Black: Standard range. Grey: Other possibilities.						

## FLOW

Table 1. Regulator flow in (n)m<sup>3</sup>/h natural gas, with internal signal (12).

Table 2. Regulator flow in (n)m<sup>3</sup>/h natural gas, with internal signal (12) + external signal (25).

The speed of the gas flowing through the outlet pipe where the pressure is taken to drive the regulator (25), (and Shut-off valve) must be less than 12 m/s.

The accuracy class is AC10 / SG20

### SUTON 4000 □3

Table 1

P <sub>a</sub> (bar)	P <sub>e</sub> (bar)															
	1.0	1.5	2.0	2.5	3.0	3.5	4.0	4.5	5.0	6.0	7.0	8.0	10	12	14	16
0.10	380	515	618	721	747	747	747	747	747	747	747	747	747	747	747	747
0.15	375	515	618	721	781	781	781	781	781	781	781	781	781	781	781	781
0.20	369	515	618	721	815	815	815	815	815	815	815	815	815	815	815	815
0.25	362	515	618	721	824	849	849	849	849	849	849	849	849	849	849	849
0.30	355	483	618	721	824	883	883	883	883	883	883	883	883	883	883	883
0.35	347	478	618	721	824	917	917	917	917	917	917	917	917	917	917	917

### Flow in (n)m<sup>3</sup>/h natural gas

#### Flow with other gases

In the tables above, the flow is in (n)m<sup>3</sup>/h natural gas with a density 0.61 and temperature 15° C

To convert to other gas flow, using the following formula:

$$Q \text{ (n)m}^3/\text{h natural gas} \times F_c = Q \text{ (n)m}^3/\text{h n gas}$$

Example:

$$Q \text{ (n)m}^3/\text{h natural gas} \times 0.78 = Q \text{ (n)m}^3/\text{h air}$$

$$1 \text{ (n)m}^3/\text{h natural gas} = 0.78 \text{ (n)m}^3/\text{h air}$$

Correction factor F <sub>c</sub> at 15°C	
Butane	0.55
Propane	0.64
Oxygen	0.76
Air	0.78
Nitrogen	0.81
Biogas	0.85
Town gas	1.23
Hydrogen	3.04

## DIMENSIONS AND WEIGHTS

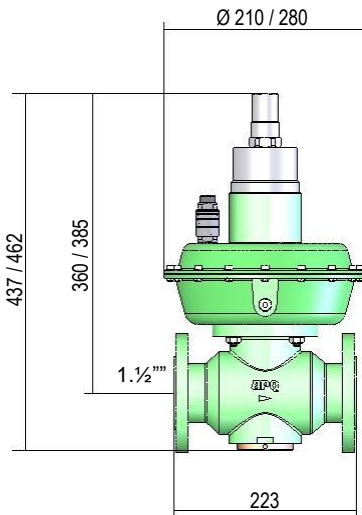

4000 □3

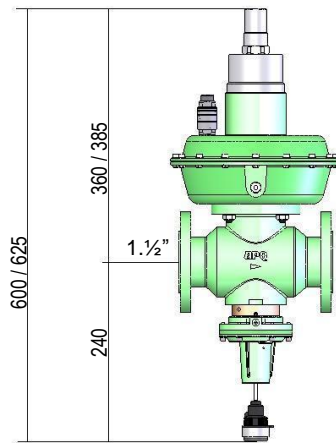

4010 □3

### Technical features of SUTON 4000 □3

bpu	0.2 ÷ 25 bar	(inlet pressure range)
Ps	25 bar	(design pressure)
Pu	25 bar	(maximum inlet pressure)
Wd		(outlet pressure range)
SUTON 4000 □3	80 ÷ 350 mbar	
Wdo	180 ÷ 800 mbar	(OPSO range)
Wdu	35 ÷ 400 mbar	(UPSO range)
Wrv	+10 ÷ +20% Pd	(Relief valve range)
Ac	until 10 %	(accuracy class)
Sg	until 20 %	(accuracy class)
T	-20°C ÷ 60°C	(working temperature)

Inlet connection	1.1/2" ANS or DN-40 PN-25
Outlet connection	1.1/2" ANS or DN-40 PN-25
Connections position	Axial
Weight SUTON-4000 □3	20.0 Kg
Weight SUTON-4010 □3	22.0 Kg

## RELIEF VALVE

For installations ON-OFF, the output of the regulator should be sufficiently large lungs to absorb water hammer. It is recommended that lung mounted external relief valve capable of removing pressure peaks.

The quantity of gas released by pressure relief valve is related to the difference of inlet pressure and his calibrated. In the attached image is shown as an example, the relief valve VS 25 model. In which its operation is based on the confrontation of forces on both sides of the membrane.

On one side of the membrane, the gas pressure acts, on the opposite side and the spring force adjustment.

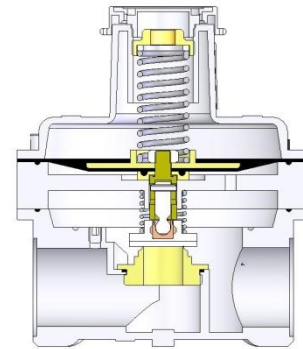

External relief valve VS-25



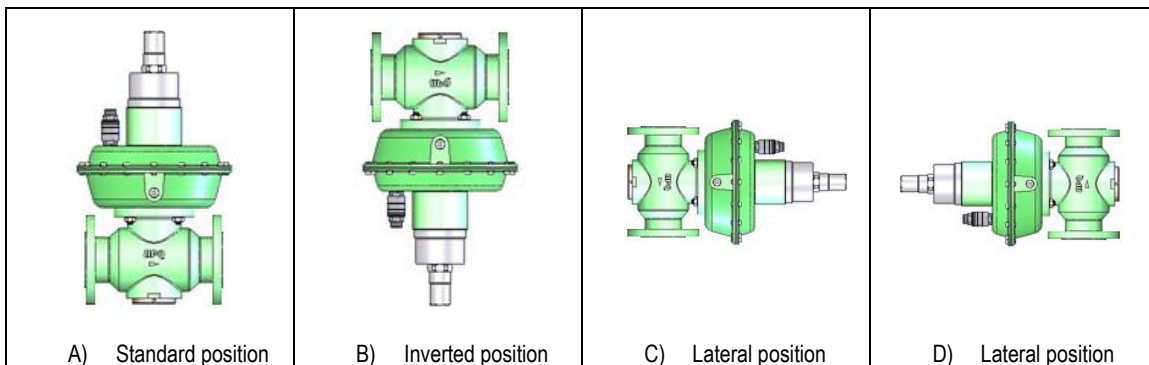

## MOUNTING POSITION

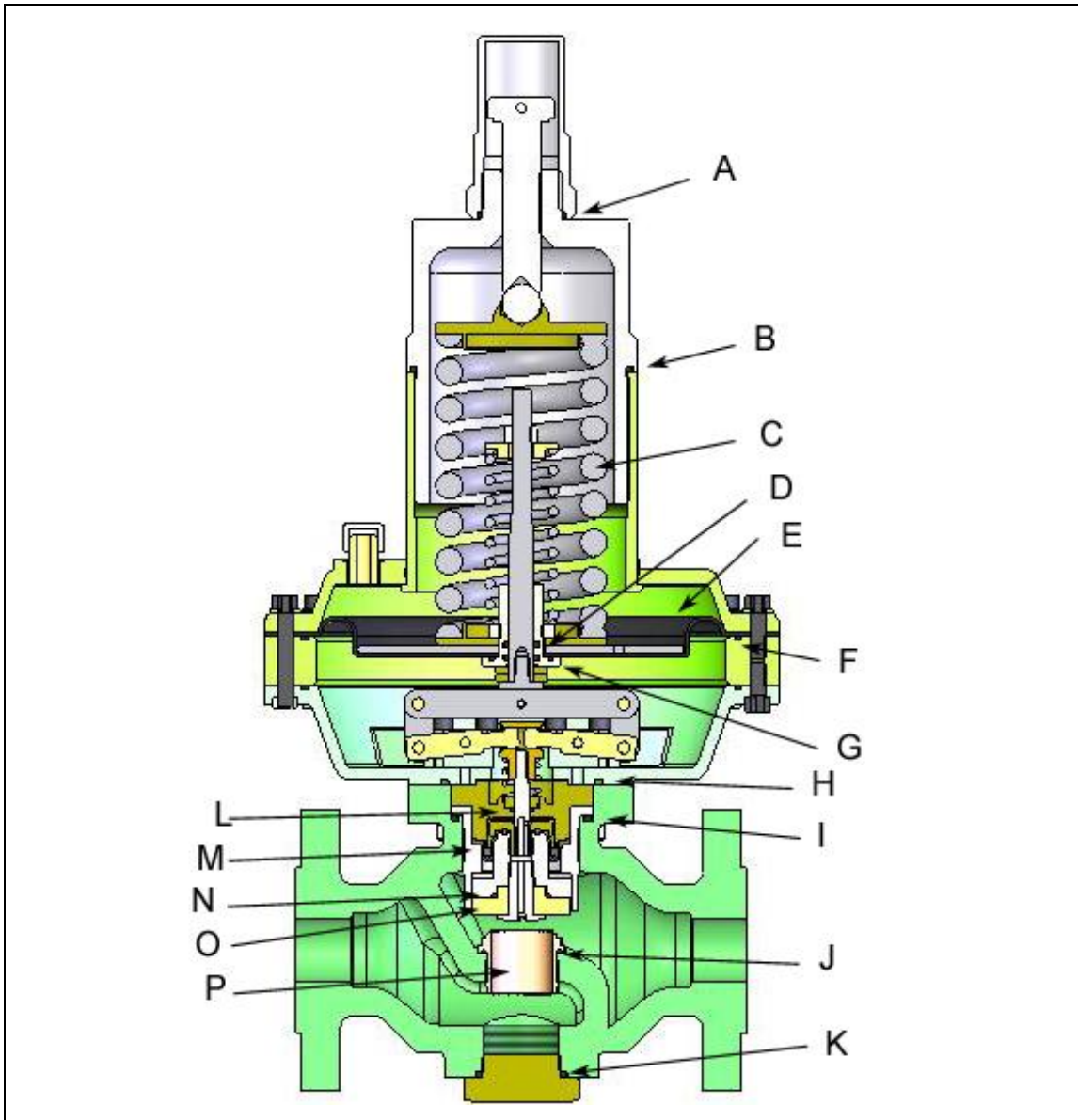

For correct operation, the regulator must be mounted according to the above figures; the first image (A) is the usual position of mounting. There should be enough space for the maintenance work.

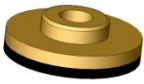

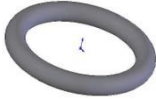
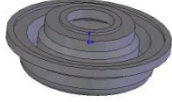
SPARE PARTS FOR SUTON 4000□3

 <p>Seat Disc (O) Code: ZM.1.00.6544</p>	 <p>Orifice (P) Code: ZM.1.00.1538</p>	 <p>Construction O-rings</p> <table border="0"> <thead> <tr> <th>Item</th> <th>Code</th> </tr> </thead> <tbody> <tr><td>A</td><td>ZM.1.00.0843</td></tr> <tr><td>B</td><td>ZM.1.00.1428</td></tr> <tr><td>D</td><td>ZM.1.00.0974</td></tr> <tr><td>F</td><td>ZM.1.00.0508</td></tr> <tr><td>G</td><td>ZM.1.00.0893</td></tr> <tr><td>H</td><td>ZM.1.00.0509</td></tr> <tr><td>I</td><td>ZM.1.00.1820</td></tr> <tr><td>J</td><td>ZM.1.00.1355</td></tr> <tr><td>K</td><td>ZM.1.00.3336</td></tr> <tr><td>L</td><td>ZM.1.00.1341</td></tr> <tr><td>N</td><td>ZM.1.00.0047</td></tr> </tbody> </table>	Item	Code	A	ZM.1.00.0843	B	ZM.1.00.1428	D	ZM.1.00.0974	F	ZM.1.00.0508	G	ZM.1.00.0893	H	ZM.1.00.0509	I	ZM.1.00.1820	J	ZM.1.00.1355	K	ZM.1.00.3336	L	ZM.1.00.1341	N	ZM.1.00.0047
Item	Code																									
A	ZM.1.00.0843																									
B	ZM.1.00.1428																									
D	ZM.1.00.0974																									
F	ZM.1.00.0508																									
G	ZM.1.00.0893																									
H	ZM.1.00.0509																									
I	ZM.1.00.1820																									
J	ZM.1.00.1355																									
K	ZM.1.00.3336																									
L	ZM.1.00.1341																									
N	ZM.1.00.0047																									
 <p>Compensation Diaphragm (M) Code: ZM.1.00.1482</p>	 <p>Main Diaphragm (E) Code: ZM.1.00.2191</p>																									

## SAFETY SHUT-OFF DEVICE (SAV)

The SUTON 4000 □3 regulator, is available with built-in safety valve (SAV), or can also be mounted in the future if the installation conditions vary.

In the future if you want to mount the SAV, request the set RI.ORG.0402 and instead on the cap (3)

### SAV installation

- With the Open-end spanner, loosen and remove the cap (3)
- Insert the RI.ORG.0402, threading clockwise, taking care to reassemble the O-ring (A). Tighten the neck of the SAV with the spanner hook inserted into the holes (41)
- Loosen the screws (42) with a 2.5 mm Allen key and turn the SAV to connect the pressure tubing between the fitting (43) and exit the lung.
- Tighten the screws (42) with 2.5 mm Allen key.
- Connect with 10 mm diameter tube, the fitting (43) and the lung that are located at the exit, a distance at least 5 times the diameter of the lung output, taking care not to ride in this tube, gas valves that can break up the gas.

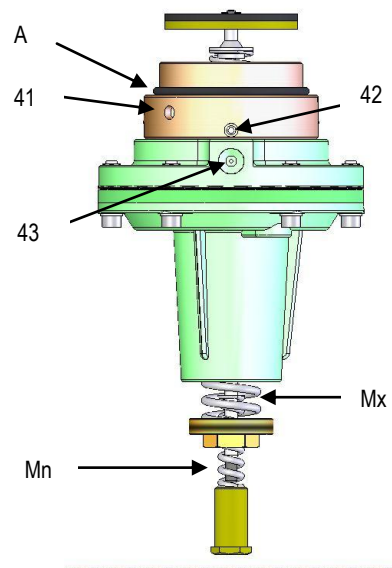

### UPS0 ADJUSTMENT SPRINGS

Spring code	Spring color	Ø Wire (mm)	Length (mm)	Ø Outside (mm)	Spring Range in kPa (mbar)
ZM.3.12.055201	Blue	2.0	55	12.3	3.5 ÷ 11 (35 ÷ 110)
ZM.3.12.055231	Black	2.3	55	12.3	5 ÷ 25 (50 ÷ 250)
ZM.3.12.055251	Purple	2.5	55	12.3	8 ÷ 40 (80 ÷ 400)

### OPSO ADJUSTMENT SPRINGS

Spring code	Spring color	Ø Wire (mm)	Length (mm)	Ø Outside (mm)	Spring Range in kPa (mbar)
ZM.3.30.060251	Green	2.5	60	30	18 ÷ 29 (180 ÷ 290)
ZM.3.30.060271	Red	2.7	60	30	23 ÷ 37 (230 ÷ 370)
ZM.3.30.060321	Yellow	3.2	60	30	30 ÷ 50 (300 ÷ 500)
ZM.3.30.060351	Blue	3.5	60	30	40 ÷ 80 (400 ÷ 800)

**WARNING!** It is potentially dangerous to manipulate a gas installation and its components. Therefore all start-up, adjustments and maintenance of the regulator must be carried out by duly authorized people with sufficient technical knowledge.