

DESCRIPTION

The RISUT2500□□PL is a piloted regulator designed for use in distribution networks with medium to high inlet pressures. Consist of a pilot system with integral adjustable pre regulator (1) and the regulator block or body (2) where the servo motor is located, the regulation body is connected to the gas pipelines.

The RISUT2510□□PL versions include an optional Over-Pressure (OPSO) and/or Under-Pressure (UPSO) Shut-Off facility, which takes the place of the lower body plug (3).

MODELS

There is one exclusive regulator model with three different pilots that cover common pressure ranges for gas installations. The pilot system consists of a pre-pilot (or pre regulator) and a main pilot.

There is one pre-pilot model:

- PR-3 (with a max inlet pressure of 20 bar, outlet pressure $0.7 \div 5$ bar)

There are three main pilot models:

- PL-1 (outlet pressure $40 \div 100$ mbar)
- PL-3 (outlet pressure $100 \div 1000$ mbar)
- PL-5 (outlet pressure $1000 \div 4000$ mbar)

CONNECTIONS

Model SUTON 2500A□PL is with 1" ANSI-150 flanges
Model SUTON 2500D□PL is with DN-25 PN-25 flanges

ASSEMBLY (fig. 1)

- Prior to installing the regulator, please verify the pressure and connection details required correspond with the information on the label (4).
- Assure that the fluid flows in the direction that the arrow (5) indicates.
- Make the connection of the sense lines (6 & 7) to a straight pipeline, turbulence free, downstream the outlet of the regulator (at a distance of at least 5 times the diameter of the pipe). The sense line tube should have a minimum diameter of 10mm and should be totally exempted of any type of obstruction, valves and diameter reductions.
- The area of installation of the regulator should be adequate to allow maintenance labors and outlet pressure adjustments.
- The OPSO/UPSO Device (Optional) is mounted on the lower section of the regulator. It monitors the downstream pressure independently of the main section of the regulator.
- The OPSO/UPSO device can be ordered with the regulator, or can be fitted separately, later if required.

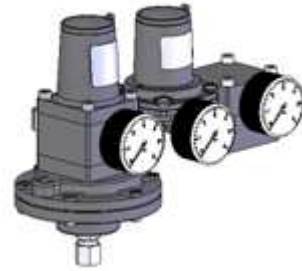
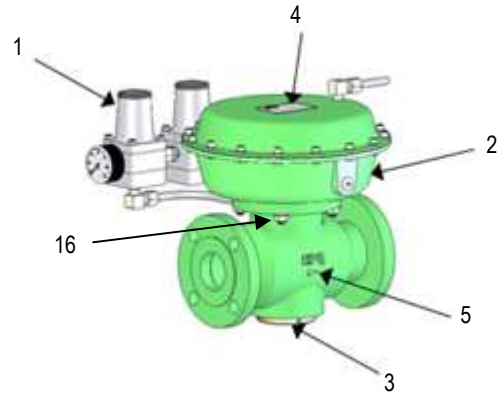

FL-1+PR-3+PL-1



FL-1+PR-3+PL-3

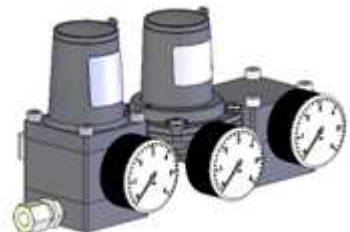

FL-1+PR-3+PL-5

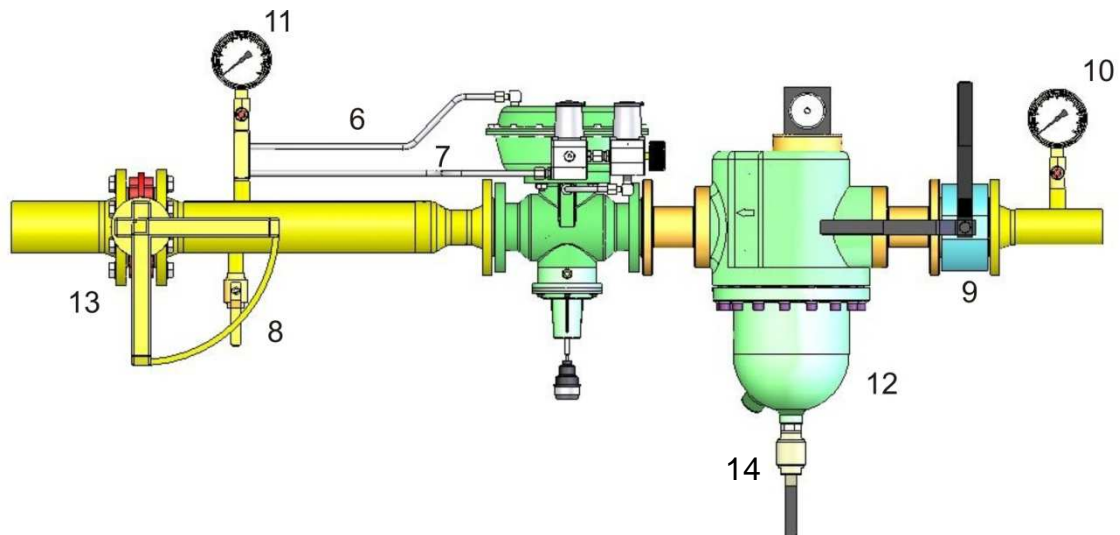

APPLICATIONS

These regulators are used for natural gas, manufactured gas, LGP, air or other type of gases which do not contain high concentration of benzene. The most important characteristics are:

- High precision, AC.
- "Fail to close" type, system that grant the equipment an extra security.
- Simple outlet pressure adjustment by replacing the pre-pilot and main pilot spring.
- Balanced type regulation and pilot orifice, which grants stability in the presence of inlet pressure variations.
- Small size in relation with the flow capacity.

STARTUP PROCEDURE

- Open the bleed valve (8) to provide a slight flow of gas.
- Slightly and slowly, open the inlet valve (9), located upstream the regulator.
- Check that the inlet pressure (10) is correct.
- Verify that the outlet pressure (11) has stabilized.
- The main inlet valve (9), found at the inlet of the filter (12), can now be fully opened.
- Slowly open the outlet valve (13).
- If the regulator is fitted with an OPSO/UPSO, refer to OPSO/UPSO device manual (startup procedure section).
- If the regulator action is extremely slow, lightly increase the pressure of the pre-pilot.
- If the outlet pressure fluctuates, reduce the pressure of the pre-pilot.

CAUSES OF ABNORMAL OPERATION

- Sense line of the pilot (7) or sense line of the regulator (6) not connected, blocked or leaking.
- Sense line of the pilot (7) or sense line of the regulator (6) may be of insufficient diameter, or connected at a location of turbulence in the pipeline.
- Pressure required is outside the range of the springs installed in the pre-pilot or pilot.
- Flow capacity requires exceeds regulator capacity.

If the pre-pilot does not close perfectly, this may be caused by:

- Orifice may be worn.
- O-ring may be worn.

If the pilot does not close perfectly, this may be caused by:

- A worn, damaged, or pitted Valve Seat Disc.

If regulator does not close perfectly, this may be caused by:

- A worn, damaged, or pitted Valve Seat Disc.
- Orifice may be worn.
- O-ring may be worn.
- Deterioration of the main or compensation diaphragms.

If the OPSO/UPSO does not close perfectly:

- Please refer to the Technical Data Sheet relevant to the OPSO/UPSO device concerned.

To avoid particle damage of the internal working parts of the regulator, it is necessary to install a filter (12) of not less than 5 microns prior to the regulator.

SUTON 2500□□PL Flow Chart

Cg C1	1480 36	Inlet Pressure (bar)												
		0.5	1	1.5	2.0	2.5	3.0	4.0	6.0	10.0	13.0	16.0		
Outlet Pressure (mbar)	20	217	271	271	271	271	271	271	271	271	271	271	271	271
	50	212	279	279	279	279	279	279	279	279	279	279	279	279
	100	203	292	292	292	292	292	292	292	292	292	292	292	292
	150	193	305	305	305	305	305	305	305	305	305	305	305	305
	200	182	311	318	318	318	318	318	318	318	318	318	318	318
	250	168	305	332	332	332	332	332	332	332	332	332	332	332
	300	153	298	345	345	345	345	345	345	345	345	345	345	345
	500	-	264	389	398	398	398	398	398	398	398	398	398	398
	700	-	215	361	451	451	451	451	451	451	451	451	451	451
	1000	-	-	303	440	531	531	531	531	531	531	531	531	531
	1500	-	-	-	337	486	609	663	663	663	663	663	663	663
	2000	-	-	-	-	368	529	777	796	796	796	796	796	796
	2500	-	-	-	-	-	397	707	928	928	928	928	928	928
	3000	-	-	-	-	-	-	605	1061	1061	1061	1061	1061	1061
	3500	-	-	-	-	-	-	449	1050	1194	1194	1194	1194	1194
4000	-	-	-	-	-	-	-	972	1326	1326	1326	1326	1326	

(n)m³/h natural gas

CHANGING THE MOBILE ASSEMBLY BALANCING DEVICE

Removal Procedure

- Close inlet Valve (9) and outlet Valve (13).
- Depressurize the inlet and outlet side of the regulator via purge valves (8 & 14).
- Disconnect the sense line that provides gas to the pre-pilot with a 19 mm open-end spanner.
- Disconnect the sense line connected to the main diaphragm with a 19 mm open-end spanner.
- Using a 17mm spanner, loosen and remove the four body bolts (16).
- Carefully pull-up the regulation motor together with the balancing device and extract it from the body of the valve.

Assembly

- Once the maintenance is done, insert the balancing device in body of the valve making pressure over it.
- Invert the "Removal Procedure".

ADJUSTMENT OF THE PILOT SYSTEM

The pilot system consists of a pre-pilot (17) and a main pilot (20). The pre-pilot function is to feed the pilot with constant pressure, even though the inlet pressure of the installation fluctuates. The function of the pilot is to feed the regulation motor of the regulator maintaining the outlet pressure without fluctuation, independently from the demanded flow. It's important that the regulator is the adequate for the require flow.

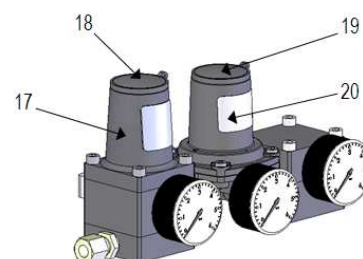

CHANGING THE REGULATION SPRINGS FORM THE PRE-PILOT OR PILOT

Disassembly

- Close the inlet valve (9).
- Close the outlet valve (13).
- Depressurize the inlet part via purge valve (14) of the filter (12).
- Depressurize the outlet part via purge valve (8).
- Remove the cap (18 or 19) to access the regulation bolts (21 or 22).
- Wind the adjustment bolt (21 or 22) anti-clockwise, until all pressures is taken off, and remove the spring.

Assembly

- Insert the spring of appropriate outlet pressure range.
- Re-assemble the main spring housing in reverse order to the above instructions.
- Please ensure only spring of appropriate size are fitted as failure to do so may cause regulator damage or failure.

DIMENSIONS AND WEIGHTS

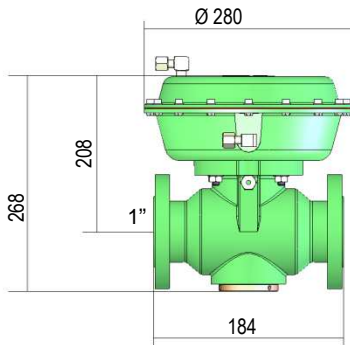

2500 PL

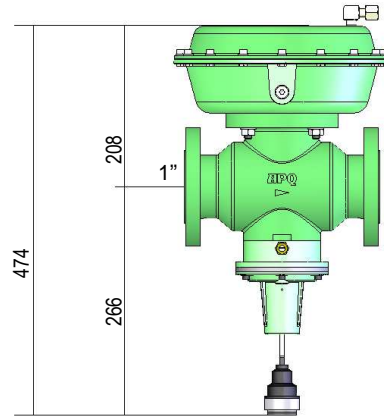

2510 PL

Technical features of SUTON 2500□□PL

bpu	0.2 ÷ 20 bar	(inlet pressure range)
Ps	20 bar	(design pressure)
Pu	20 bar	(maximum inlet pressure)
Wd		(outlet pressure range)
SUTON 2500□□PL	20 ÷ 4000 mbar	
Wdo	40 ÷ 4000 mbar	(OPSO range)
Wdu	10 ÷ 2500 mbar	(UPSO range)
Ac	until 5 %	(accuracy class)
Sg	until 10 %	(accuracy class)
T	-20°C ÷ 60°C	(working temperature)

Inlet connection	1" ANSI-150 or DN-25 PN-25
Outlet connection	1" ANSI-150 or DN-25 PN-25
Connections position	Axial
Weight SUTON-5000□□PL	00.0 Kg
Weight SUTON-5010□□PL	00.0 Kg

RELIEF VALVE

For installations ON-OFF, the output of the regulator should be sufficiently large lungs to absorb water hammer. It is recommended that lung mounted external relief valve capable of removing pressure peaks.

The quantity of gas released by pressure relief valve is related to the difference of inlet pressure and his calibrated. In the attached image is shown as an example, the relief valve VS 25 model. In which its operation is based on the confrontation of forces on both sides of the membrane.

On one side of the membrane, the gas pressure acts, on the opposite side and the spring force adjustment.

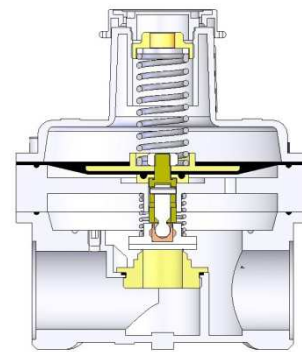

External relief valve VS-25

MOUNTING POSITION

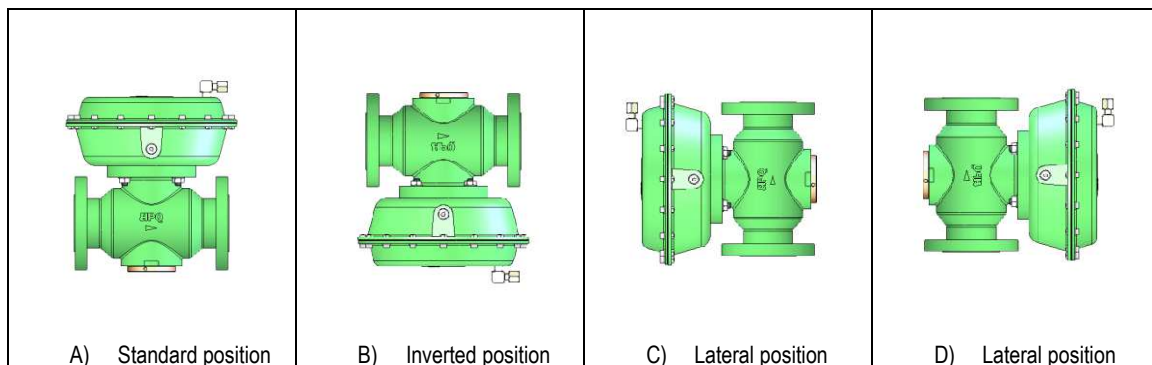

For correct operation, the regulator must be mounted according to the above figures; the first image (A) is the usual position of mounting. There should be enough space for the maintenance work.



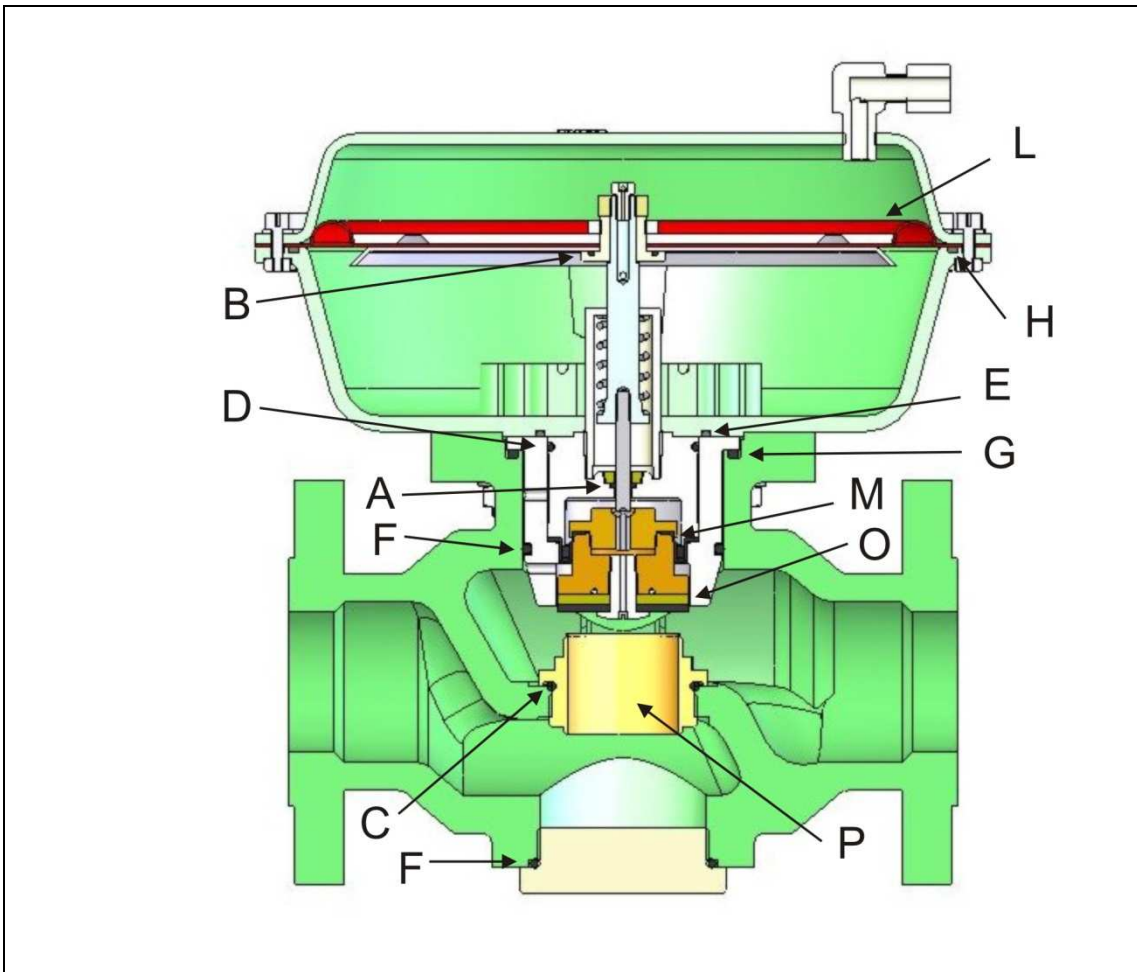

REGULATOR SUTON 2500□□PL SECTION



SPARE PARTS FOR SUTON 2500□□PL REGULATOR

 <p>Seat Disc (O) Code ZM.1.00.2883P</p>	 <p>Orifice (P) Code ZM.1.00.2171</p>	 <p>Position Reference A ZM.1.00.1341 B ZM.1.00.0893 C ZM.1.00.1288 D ZM.1.00.2173 E ZM.1.00.0509 F ZM.1.00.3053 G ZM.1.00.0237 H ZM.1.00.3159</p>
 <p>Compensation Diaphragm (M) Code ZM.1.00.2007</p>	 <p>Diaphragm (L) Code ZM.1.00.2191A</p>	

TOOLS REQUIRED FOR THE MAINTAINANCE OF THE SUTON 2500□□PL REGULATOR

 <p>Hook Spanner 90-155</p>	 <p>O-ring Extractor</p>	 <p>Allen Key 4 - 5</p>	 <p>Tube Spanner 13-24-46</p>	 <p>Open-end Spanner 17 - 19 - 27</p>
--	---	--	---	--

FILTER FL-1

Be controlled by the regulator at work, which in the filter, the pressure loss does not exceed 0.2 bar. Otherwise proceed to replace the filter element.

FILTER REPLACEMENT

Disassembly



- Close the inlet valve (9).
- Close the outlet valve (13).
- Depressurize the inlet part via purge valve (14) of the filter (12).
- Depressurize the outlet part via purge valve (8).
- Remove the filter screws with a 5mm Allen key.
- Remove the filtration element (A) and clean the support grid.

Assembly

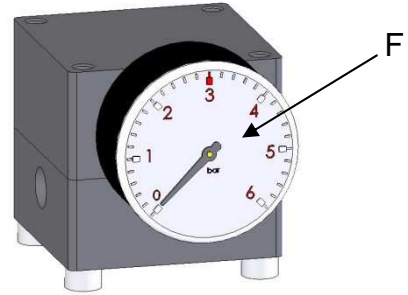
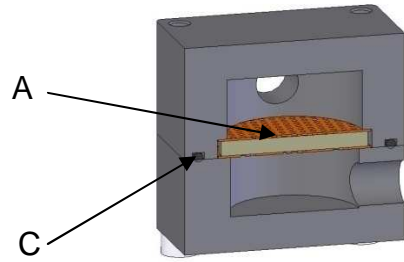
- Re-assembly the filter in reverse order to the above instructions, taking special attention with the O-ring seal.



SPARE PARTS FOR THE FILTER FL-1

		
Filtration element (A) Reference ZM.1.00.1319	O ring (C) Reference ZM.1.00.1322	Gauge (F) F. scale Reference 0 - 4 bar WI.1.05.0040 0 - 10 bar WI.1.05.0100 0 - 16 bar WI.1.05.0160 0 - 25 bar WI.1.05.0250

PRE-PILOT PR-3

The pre-pilot pressure value should be adjusted 0.3 to 0.5 bar over the regulation pressure, for that the plastic cap (18) should be extracted and with a 22 mm tube spanner adjust the pressure turning the nut (21). Rotating it clockwise the pre-pilot pressure will increase, and anti-clockwise will decrease. We can control the pressure in the lateral gauge (F). Once the pressure is adjusted, assemble again the plastic cap (18).

The adjustment springs (24) of the pre-pilot have their own regulation range. In cases where the pre-pilot regulation pressure should vary significantly, the spring should be replaced.

The inlet connection should be in position (25).

The outlet connection (pre-regulated pressure) position (26).

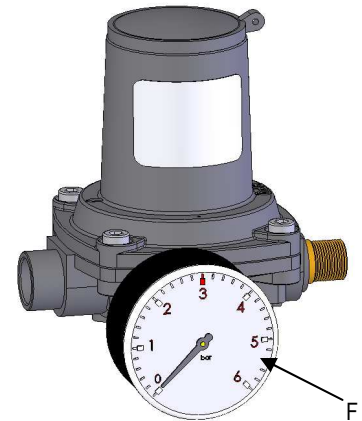
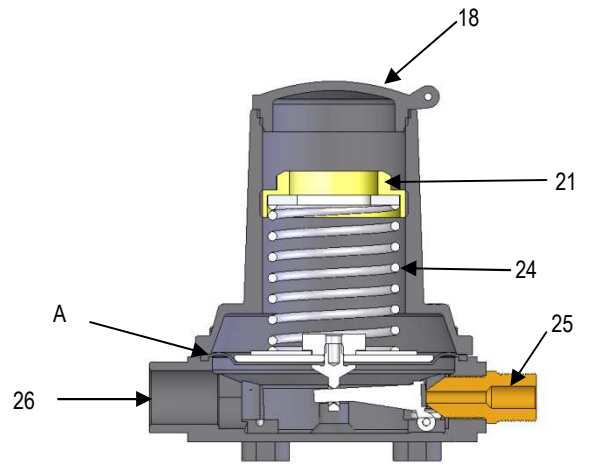

PRE-PILOT PR-3 PRESSURE ADJUSTMENT SPRINGS

Spring Reference	Spring Color	Ext. Ø	L	Wire Ø	n° of turns	Spring Range (bar)
ZM330060351	Blue	30	60	3.5	8	0.7 ÷ 2.0
ZM330060371	Black	30	60	3.7	8	1.3 ÷ 2.5
ZM330060401	Purple	30	60	4.0	8	2.0 ÷ 4.0
M330060421	Silver	30	60	4.2	8	2.5 ÷ 5.0

SPARE PARTS FOR THE PRE-PILOT PR-3

<p>Diaphragm (A) Code ZM.1.00.1300</p>	<p>O rings</p> <table border="0"> <tr> <td>Position</td> <td>Reference</td> </tr> <tr> <td>(C)</td> <td>ZM.1.00.1322</td> </tr> <tr> <td>(D)</td> <td>ZM.1.00.0712</td> </tr> <tr> <td>(E)</td> <td>ZM.1.00.1402</td> </tr> </table>	Position	Reference	(C)	ZM.1.00.1322	(D)	ZM.1.00.0712	(E)	ZM.1.00.1402	<p>Gauge (F)</p> <table border="0"> <tr> <td>F. scale</td> <td>Reference</td> </tr> <tr> <td>1.0 bar</td> <td>WI.1.05.0010</td> </tr> <tr> <td>1.6 bar</td> <td>WI.1.05.0016</td> </tr> <tr> <td>2.5 bar</td> <td>WI.1.05.0025</td> </tr> <tr> <td>4.0 bar</td> <td>WI.1.05.0040</td> </tr> <tr> <td>6.0 bar</td> <td>WI.1.05.0060</td> </tr> </table>	F. scale	Reference	1.0 bar	WI.1.05.0010	1.6 bar	WI.1.05.0016	2.5 bar	WI.1.05.0025	4.0 bar	WI.1.05.0040	6.0 bar	WI.1.05.0060
Position	Reference																					
(C)	ZM.1.00.1322																					
(D)	ZM.1.00.0712																					
(E)	ZM.1.00.1402																					
F. scale	Reference																					
1.0 bar	WI.1.05.0010																					
1.6 bar	WI.1.05.0016																					
2.5 bar	WI.1.05.0025																					
4.0 bar	WI.1.05.0040																					
6.0 bar	WI.1.05.0060																					

TOOLS FOR PRE PILOT PR-3 MAINTAINANCE

<p>Allen Key 3 - 5</p>	<p>O ring extractor</p>	<p>Open-end Spanner 14-19</p>	<p>Tube Spanner 10 - 22</p>
----------------------------	-------------------------	-----------------------------------	---------------------------------

PILOT PL-1

The pilot PL-1 should have three connections. The feeding entrance (27) that should be connected to the pre-pilot exit (26). An exit to the motorization chamber (28) that is mounted in the opposite side of the main body to facilitate the installation (the out of service connections have a plastic cap), and the last connection in the lower part of the pilot (29) that should be connected downstream the regulator.

The pilot should be adjusted to the desired regulation pressure, to adjust the pressure remove the plastic cap (19) and with a 22 mm tube spanner adjust the pressure by rotating the nut. Rotating it clockwise the pressure will increase and anti-clockwise will decrease. The outlet pressure can be controlled with the gauge (F). Once the pressure is adjusted relocate the plastic cap (19).

The adjustment springs (30) of the pilot have their own regulation range. In cases where the pre-pilot regulation pressure should vary significantly, the spring should be replaced.

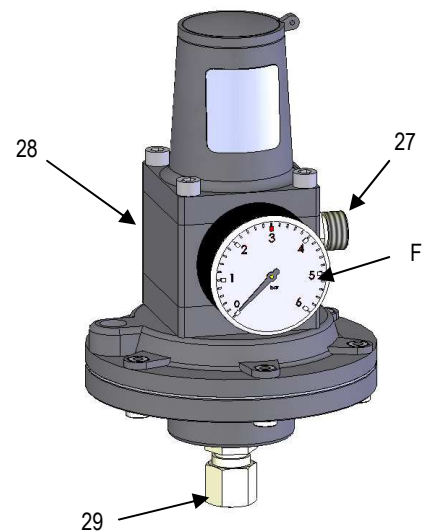
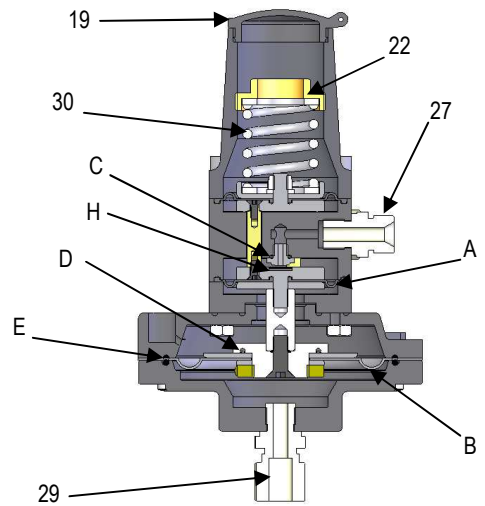

PILOT PL-1 PRESSURE ADJUSTMENT SPRINGS

Spring Reference	Spring Color	Ext. Ø	L	Wire Ø	n° of turns	Spring Range (mbar)
ZM3300600171	Red	30	60	1.7	5.5	40 ÷ 100

SPARE PARTS FOR THE PILOT PL-1

<p>Diaphragm (A) Ref. ZM.1.00.1300</p>	<p>Diaphragm (B) Ref. ZM.1.00.1156</p>	<p>O rings Position Reference (C) ZM.1.00.1572 (D) ZM.1.00.0048 (E) ZM.1.00.0675</p>	<p>Seat Disc (H) Ref. ZM.1.00.3108</p>	<p>Gauge (F) F. scale Reference 160 Mbar WI.0.05.0160</p>
--	--	--	--	---

TOOLS FOR PILOT PL-1 MAINTAINANCE

<p>Allen Key 3 - 5</p>	<p>O ring extractor</p>	<p>Open-end Spanner 14-19</p>	<p>Tube Spanner 10 - 22</p>	<p>Phillips Screwdriver</p>
----------------------------	-------------------------	-----------------------------------	---------------------------------	-----------------------------

PILOTO PL-3

The pilot PL-3 should have three connections. The feeding entrance (27) that should be connected to the pre-pilot exit (26). An exit to the motorization chamber (28) that is mounted in the opposite side of the main body to facilitate the installation (the out of service connections have a plastic cap), and the last connection in the lower part of the pilot (29) that should be connected downstream the regulator.

The pilot should be adjusted to the desired regulation pressure, to adjust the pressure remove the plastic cap (19) and with a 22 mm tube spanner adjust the pressure by rotating the nut. Rotating it clockwise the pressure will increase and anti-clockwise will decrease. The outlet pressure can be controlled with the gauge (F). Once the pressure is adjusted relocate the plastic cap (19).



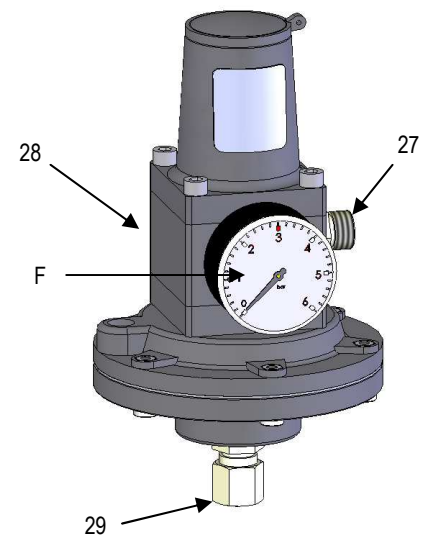
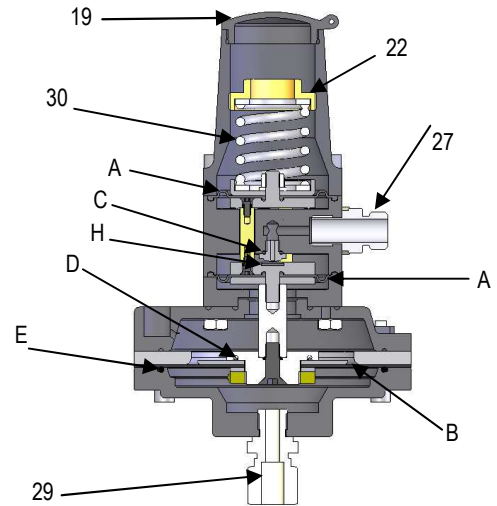

The adjustment springs (30) of the pilot have their own regulation range. In cases where the pre-pilot regulation pressure should vary significantly, the spring should be replaced.







PILOTO PL-3 PRESSURE ADJUSTMENT SPRINGS

Spring Reference	Spring Color	Ext. Ø	L	Wire Ø	n° of turns	Spring Range (mbar)
ZM330060221	Silver	30	60	2.2	6	100 ÷ 300
ZM330060251	Green	30	60	2.5	6.5	150 ÷ 400
ZM330060271	Red	30	60	2.7	7	200 ÷ 600
ZM330060301	White	30	60	3.0	7.5	400 ÷ 1000

SPARE PARTS FOR THE PILOTO PL-3

 Diaphragm (A) Ref. ZM.1.00.1300	 Diaphragm (B) Ref. ZM.1.00.2966	 O rings Position Reference (C) ZM.1.00.1572 (D) ZM.1.00.0048 (E) ZM.1.00.0675	 Seat Disc (H) Ref. ZM.1.00.3108	 Gauge (F) F. scale Reference 160 mbar WI.0.05.0160 250 mbar WI.0.05.0250 400 mbar WI.0.05.0400 600 mbar WI.0.05.0600 1.0 bar WI.1.05.0010 1.6 bar WI.1.05.0016
---	---	--	---	--

TOOLS FOR PILOTO PL-3 MAINTAINANCE

 Allen Key 3 - 5	 O ring extractor	 Open-end Spanner 14-19	 Tube Spanner 10 - 22	 Phillips Screwdriver
---	---	--	---	---

PILOT PL-5

The pilot PL-5 should have three connections. The feeding entrance (27) that should be connected to the pre-pilot exit (26). An exit to the motorization chamber (28) that is mounted in the opposite side of the main body to facilitate the installation (the out of service connections have a plastic cap), and the last connection in the lower part of the pilot (29) that should be connected downstream the regulator.

The pilot should be adjusted to the desired regulation pressure, to adjust the pressure remove the plastic cap (19) and with a 22 mm tube spanner adjust the pressure by rotating the nut. Rotating it clockwise the pressure will increase and anti-clockwise will decrease. The outlet pressure can be controlled with the gauge (F). Once the pressure is adjusted relocate the plastic cap (19).

The adjustment springs (30) of the pilot have their own regulation range. In cases where the pre-pilot regulation pressure should vary significantly, the spring should be replaced.

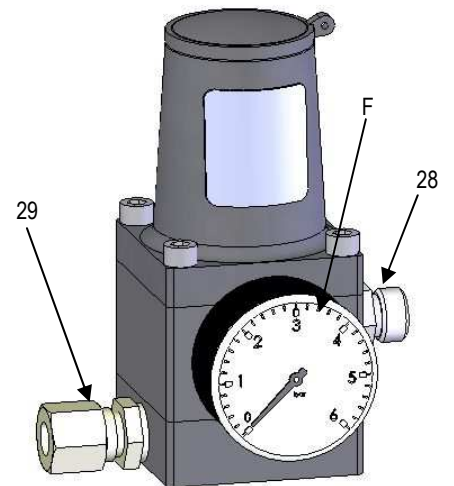
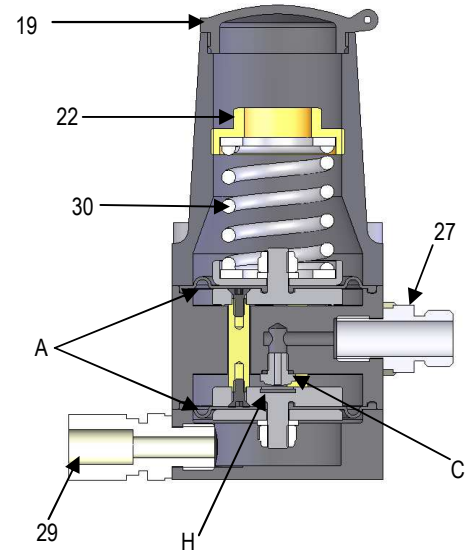

PILOT PL-5 PRESSURE ADJUSTMENT SPRINGS

Spring Reference	Spring Color	Ext. Ø	L	Wire Ø	n° of turns	Spring Range (bar)
ZM330060351	Blue	30	60	3.5	8	0.7 ÷ 2.0
ZM330060371	Black	30	60	3.7	8	1.3 ÷ 2.5
ZM330060401	Purple	30	60	4.0	8	2.0 ÷ 4.0
ZM330060421	Nickel	30	60	4.2	8	2.5 ÷ 5.0

SPARE PARTS FOR THE PILOT PL-5

<p>Diaphragm (A) Reference ZM.1.00.1300</p>	<p>Seat Disc (H) Reference ZM.1.00.3108</p>	<p>O rings (C) Reference ZM.1.00.1572</p>	<p>Gauge (F) F. scale Reference</p> <table border="0"> <tr> <td>1.0 bar</td> <td>WI.1.05.0010</td> </tr> <tr> <td>1.6 bar</td> <td>WI.1.05.0016</td> </tr> <tr> <td>2.5 bar</td> <td>WI.1.05.0025</td> </tr> <tr> <td>4.0 bar</td> <td>WI.1.05.0040</td> </tr> <tr> <td>6.0 bar</td> <td>WI.1.05.0060</td> </tr> </table>	1.0 bar	WI.1.05.0010	1.6 bar	WI.1.05.0016	2.5 bar	WI.1.05.0025	4.0 bar	WI.1.05.0040	6.0 bar	WI.1.05.0060
1.0 bar	WI.1.05.0010												
1.6 bar	WI.1.05.0016												
2.5 bar	WI.1.05.0025												
4.0 bar	WI.1.05.0040												
6.0 bar	WI.1.05.0060												

TOOLS FOR PILOT PL-5 MAINTAINANCE

<p>Allen Key 3 - 5</p>	<p>O ring extractor</p>	<p>Open-end Spanner 14-19</p>	<p>Tube Spanner 10 - 22</p>	<p>Phillips Screwdriver</p>
----------------------------	-------------------------	-----------------------------------	---------------------------------	-----------------------------

SAFETY SHUT-OFF DEVICE (SAV)

The SUTON 2500□□PL regulator, is available with built-in safety valve (SAV), or can also be mounted in the future if the installation conditions vary.

In the future if you want to mount the SAV, request the set RI.ORG.025□ and instead on the cap (3).

SAV installation

- With the Open-end spanner, loosen and remove the cap (3)
- Insert the RI.ORG.025□, threading clockwise, taking care to reassemble the O-ring (A). Tighten the neck of the SAV with the spanner hook inserted into the holes (41).
- Loosen the screws (42) with a 2.5 mm Allen key and turn the SAV to connect the pressure tubing between the fitting (43) and exit the lung.
- Tighten the screws (42) with 2.5 mm Allen key.
- Connect with 10 mm diameter tube, the fitting (43) and the lung that are located at the exit, a distance at least 5 times the diameter of the lung output, taking care not to ride in this tube, gas valves that can break up the gas.

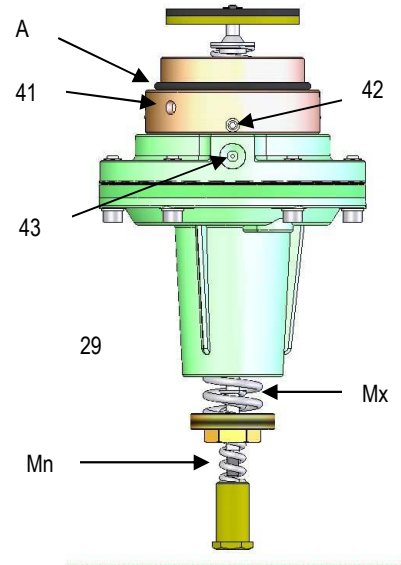

WARNING! It is potentially dangerous to manipulate a gas installation and its components. Therefore all start-up, adjustments and maintenance of the regulator must be carried out by duly authorized people with sufficient technical knowledge.

SAFETY SHUT-OFF DEVICE (SAV) UPSO/OPSO ADJUSTMENT SPRINGS:

RI.ORG.0251

USPO ADJUSTMENT SPRINGS

Spring code	Spring color	Ø Wire (mm)	Length (mm)	Ø Outside (mm)	Spring Range in kPa (mbar)
ZM313055121	-	1.25	55	12	1 ÷ 3.2 (10 ÷ 32)
ZM313055151	Yellow	1.5	55	12	2.4 ÷ 4 (24 ÷ 40)
ZM312055201	Blue	2	55	12.75	3 ÷ 11.5 (30 ÷ 115)

OPSO ADJUSTMENT SPRINGS

Spring code	Spring color	Ø Wire (mm)	Length (mm)	Ø Outside (mm)	Spring Range in kPa (mbar)
ZM3300060221	Silver	2.25	60	30	4 ÷ 13 (40 ÷ 130)
ZM3300060251	Green	2.5	60	30	6 ÷ 19 (60 ÷ 190)
ZM3300060271	Red	2.75	60	30	9 ÷ 24 (90 ÷ 240)

RI.ORG.0252

USPO ADJUSTMENT SPRINGS

Spring code	Spring color	Ø Wire (mm)	Length (mm)	Ø Outside (mm)	Spring Range in kPa (mbar)
ZM312055201	Blue	2	55	12.75	3.5 ÷ 11 (35 ÷ 110)
ZM312055231	Black	2.3	55	12.3	5 ÷ 25 (50 ÷ 250)
ZM312055251	Purple	2.5	55	12.75	8 ÷ 40 (80 ÷ 400)

OPSO ADJUSTMENT SPRINGS

Spring code	Spring color	Ø Wire (mm)	Length (mm)	Ø Outside (mm)	Spring Range in kPa (mbar)
ZM3300060251	Green	2.5	60	30	18 ÷ 29 (180 ÷ 290)
ZM3300060271	Red	2.75	60	30	23 ÷ 37 (230 ÷ 270)
ZM3300060321	Yellow	3.25	60	30	30 ÷ 50 (300 ÷ 500)
ZM3300060351	Blue	3.5	60	30	40 ÷ 80 (400 ÷ 800)

RI.ORG.0253

USPO ADJUSTMENT SPRINGS

Spring code	Spring color	Ø Wire (mm)	Length (mm)	Ø Outside (mm)	Spring Range in kPa (mbar)
ZM312055251	Purple	2.5	55	12.75	15 ÷ 50 (150 ÷ 500)
ZM312055281	Orange	2.8	55	12.3	30 ÷ 100 (300 ÷ 1000)
ZM312055301	Pink	3	55	12.5	80 ÷ 250 (800 ÷ 2500)

OPSO ADJUSTMENT SPRINGS

Spring code	Spring color	Ø Wire (mm)	Length (mm)	Ø Outside (mm)	Spring Range in kPa (mbar)
ZM3300060351	Blue	3.5	60	30	50 ÷ 100 (500 ÷ 1000)
ZM3300060371	Black	3.75	60	30	70 ÷ 130 (700 ÷ 1300)
ZM3300060401	Purple	4	60	30	100 ÷ 180 (1000 ÷ 1800)
ZM3300060451	Orange	4.5	60	30	130 ÷ 250 (1300 ÷ 2500)
ZM3300060481	Pink	4.8	60	30	180 ÷ 400 (1800 ÷ 4000)