

### DESCRIPTION

The Sutton 2V 2810□1 Regulator is designed for use in distribution networks with medium to high inlet pressures.

It is a direct acting regulator, where the spring housing/regulator head (1) is mounted directly to the flanged body (2). This flanged body has mounted two security organs.

Each of the two security organs may include Over-Pressure (OPSO) and/or Under-Pressure (UPS) Shut-Off facilities.

### MODEL

There are three models in the range, depending on the required inlet/outlet pressures.

Model BP (Low pressure version): For outlet pressures from 2 to 10 kPa (20 to 100 mbar).  
(This technical sheet)

Model MP (Medium pressure version): For outlet pressures from 8 to 40 kPa (80 to 400 mbar).  
(Please refer to technical datasheet Sutton 2V 2810□3)

Model AP (High pressure version): For outlet pressures from 30 to 400 kPa (300 to 4000 mbar).  
(Please refer to technical datasheet Sutton 2V 2810□5)

### CONNECTIONS

Model SUTON 2810 A1 is with 1" ANSI-150 flanges

Model SUTON 2810 D1 is with DN-25 PN-25 flanges

### ASSEMBLY

- Prior to installing the regulator, please verify the pressure and connection details required correspond with the information on the label (15).
- Assure that the fluid flows in the direction that the arrow (14) indicates.
- Make the connection of the sense lines (12) to a straight pipeline, turbulence free, downstream the outlet of the regulator (at a distance of at least 5 times the diameter of the pipe). The sense line tube should have a minimum diameter of 10mm and should be totally exempted of any type of obstruction, valves and diameter reductions.
- The area of installation of the regulator should be adequate to allow maintenance labors and outlet pressure adjustments.
- The OPSO/UPS Device (Optional) are mounted on the lower and lateral sections of the regulator. It monitors the downstream pressure independently of the main section of the regulator. The OPSO/UPS device can be ordered with the regulator, or can be fitted separately, later if required.

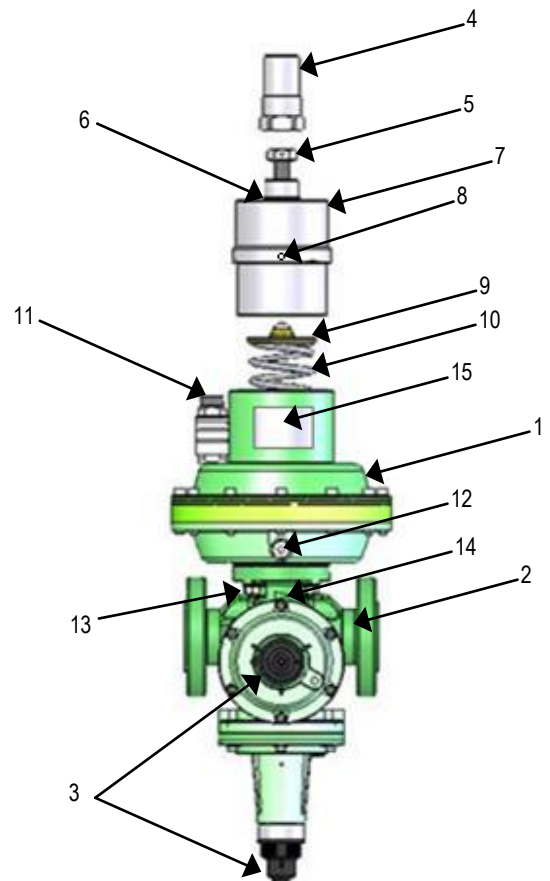
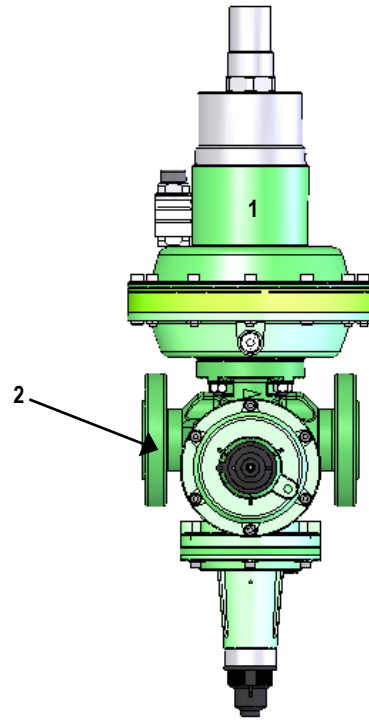

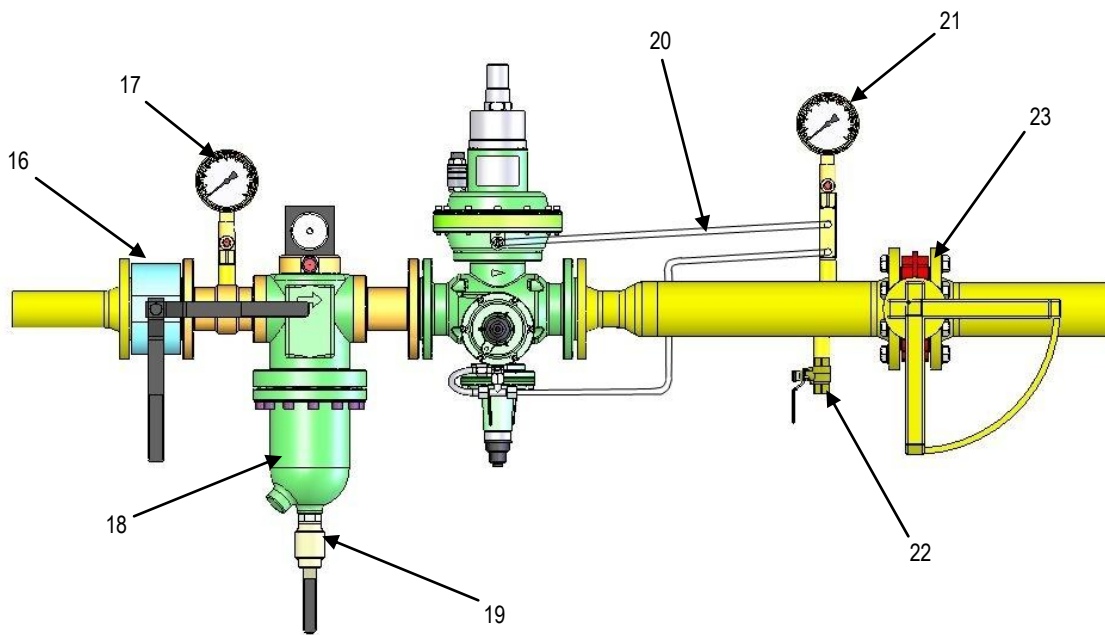

### IMPLEMENTATION OF A SYSTEM WITH OPSO + OPSO/UPS0

- The OPSO spring was mounted in the horizontal body.
- The OPSO/UPS0 springs were mounted in the vertical body.
- Open the bleed valve (22) to provide a slight flow of gas.
- Slightly and slowly, open the inlet valve (16), located immediately upstream of the regulator.
- Check that the inlet pressure (17) is correct.
- Remove the release plastic caps (3) located in the heads of the security bodies.
- Invert caps (3) and thread them at the ends of the release axes.
- Slowly pull the plastic cap (3) that corresponds to the horizontal security body and only protects for maximum pressure. Do this operation smoothly to open only the internal bypass of the obturator and slowly pressurize the section between the two security bodies. Once you have pressurized the stretch, finish pulling firmly the cap (3) to note the internal mechanical interlock.
- Slowly pull the plastic cap (3) that corresponds to the vertical security body and protects for maximum and minimum pressure. Do this operation smoothly to open only the internal bypass of the obturator and slowly pressurize the section between the second body and the shutoff valve downstream of the regulator. Once the pressure has stabilized at the outlet, finish firmly pull the cap (3) to note the internal mechanical interlock.
- Unscrew the plastic caps (3) of the release axes and inverting reassemble the heads of security bodies to protect the whole.
- Close slowly the bleed valve (22).
- Verify with the pressure gauge (21) that the outlet pressure has stabilized.
- The main inlet valve (16), found at the inlet of the filter (18), can now be fully opened slowly.
- Slowly open the outlet valve (23).

### REGULATOR SETUP

#### Outlet Pressure Adjustment:

- Remove aluminum cap (4), located on the top of the regulator (1).
- To increase outlet pressure, turn the main spring adjustment bolt (5) CLOCKWISE with a Tube Spanner 24mm.
- Turning this bolt anti-clockwise will decrease the outlet pressure. This must be done having gas consumption.
- Place aluminum cap (4) back onto the regulator top, make sure to put the O-ring (6).

The spring (10) used in these regulators have been designed to provide specific outlet pressure ranges. For outlet pressures outside the specified range, a spring change will be required.

#### Causes of abnormal operation:

- Sense lines (20) not connected, blocked or leaking.
- Sense lines (20) may be of insufficient diameter, or connected at a location of turbulence in the pipeline.
- Pressure required is outside the range of the spring installed.
- Flow capacity requires exceeds regulator capacity.
- Atmospheric Vent (11) blocked or restricted.

If regulator does not close perfectly, this may be caused by:

- A worn, damaged, or pitted Valve Seat Disc (O).
- Orifice (P) may be worn.
- O-ring may be worn.
- Deterioration of the main or compensation diaphragms.

If the OPSO/UPSO does not close perfectly:

- Please refer to the Technical Data Sheet relevant to the OPSO/UPSO device concerned.

To avoid particle damage of the internal working parts of the regulator, it is necessary to install a filter (18) of not less than 5 microns prior to the regulator.

#### **CHANGING THE MAIN SPRING:**

Removing the main spring:

- Close inlet valve (16) and the outlet valve (23).
- Depressurize the inlet and outlet side of the regulator via purge valves 19 and 22.
- Remove main regulator cap (4) to access the bolt (5).
- Wind the adjustment bolt (5) ANTI-CLOCKWISE, until all pressures is taken off the main spring.
- Using a 90 to 155mm hook-spanner, turn the main spring housing (7) anti-clockwise to reveal the main spring.
- Extract the spring.

Re-assembly

- Insert the spring of appropriate outlet pressure range.
- Re-assemble the main spring housing in reverse order to the above instructions.
- **Please ensure only spring of appropriate size are fitted, and the spring plate and ball-bearing are relocated on the top of the replacement spring, as failure to do so may cause regulator damage or failure.**







#### **REMOVAL OF THE MOBILE DEVICE:**

- Close inlet Valve (16) and outlet Valve (23).
- Depressurize the inlet and outlet side of the regulator via purge valves 19 and 22.
- Disconnect the sense line connected to the underside of the main diaphragm housing (12).
- Using a 17mm spanner, loosen and remove the four body bolts (13).
- The regulator head can now be safely removed.

Re-assembly

- To re-fit the regulator head, reverse the above procedure.

**TOOLS REQUIRED FOR THE MAINTAINANCE OF THE SUTON 2V 2810□1 REGULATORS**

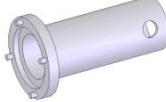
 Hook-Spanner 90-155mm	 O-ring Extractor	 Allen Key 4 - 5 mm	 Tube Spanner 13 - 24 - 46 mm
 Open-end Spanner 17 - 19 - 27 mm	 Screwdriver 10 x 1,6 mm	 Tweezers	 Orifice Key

**OUTLET PRESSURE ADJUSTMENT SPRINGS FOR THE SUTON 2V 2810□1 REGULATORS**

Spring Code	Spring Color	Ø Wire (mm)	Length (mm)	Ø Outside (mm)	n° Turns	Spring Range in kPa (mbar)
ZM.3.50.220301	Nickel + White Stripe	3	220	50	15	1 ÷ 2 (10 ÷ 20)
ZM.3.50.220351	Nickel + Yellow Stripe	3.5	220	50	15	1.5 ÷ 2.4 (15 ÷ 24)
ZM.3.50.220401	Nickel + Blue Stripe	4	220	50	15	1.4 ÷ 4 (14 ÷ 40)
ZM.3.50.220451	Nickel + Black Stripe	4.5	220	50	15	3.4 ÷ 6.5 (34 ÷ 65)
ZM.3.50.220.501	Nickel + Purple Stripe	5	220	50	15	4.5 ÷ 11 (45 ÷ 110)

## FLOW

Table 1. Regulator flow in (n)m<sup>3</sup>/h natural gas, with internal signal (12).

Table 2. Regulator flow in (n)m<sup>3</sup>/h natural gas, with internal signal (12) + external signal (25).

The speed of the gas flowing through the outlet pipe where the pressure is taken to drive the regulator (25), (and Shut-off valve) must be less than 12 m/s.

The accuracy class is AC10 / SG20

### SUTON 2V 2810 □1

Table 1

P <sub>a</sub> (bar)	P <sub>e</sub> (bar)															
	1.0	1.5	2.0	2.5	3.0	3.5	4.0	4.5	5.0	6.0	7.0	8.0	10	12	14	16
0.02	182	248	271	271	271	271	271	271	271	271	271	271	271	271	271	271
0.03	182	248	273	273	273	273	273	273	273	273	273	273	273	273	273	273
0.04	181	248	276	276	276	276	276	276	276	276	276	276	276	276	276	276
0.05	181	248	279	279	279	279	279	279	279	279	279	279	279	279	279	279
0.06	180	248	281	281	281	281	281	281	281	281	281	281	281	281	281	281
0.08	179	248	286	286	286	286	286	286	286	286	286	286	286	286	286	286
0.10	178	248	292	292	292	292	292	292	292	292	292	292	292	292	292	292

### Flow in (n)m<sup>3</sup>/h natural gas

#### Flow with other gases

In the tables above, the flow is in (n)m<sup>3</sup>/h natural gas with a density 0.61 and temperature 15° C

To convert to other gas flow, using the following formula:

$$Q \text{ (n)m}^3\text{/h natural gas} \times F_c = Q \text{ (n)m}^3\text{/h n gas}$$

Example:

$$Q \text{ (n)m}^3\text{/h natural gas} \times 0.78 = Q \text{ (n)m}^3\text{/h air}$$

$$1 \text{ (n)m}^3\text{/h natural gas} = 0.78 \text{ (n)m}^3\text{/h air}$$

Correction factor F <sub>c</sub> at 15°C	
Butane	0.55
Propane	0.64
Oxygen	0.76
Air	0.78
Nitrogen	0.81
Biogas	0.85
Town gas	1.23
Hydrogen	3.04

## DIMENSIONS AND WEIGHTS

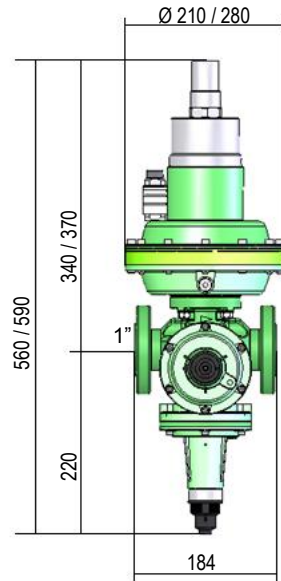

SUTON 2V 2810 □1

### Technical features of SUTON 2V 2810 □1

bpu	0.2 ÷ 25 bar	(inlet pressure range)
Ps	25 bar	(design pressure)
Pu	25 bar	(maximum inlet pressure)
Wd		(outlet pressure range)
SUTON 2V 2810 □1	20 ÷ 100 mbar	
Wdo	40 ÷ 240 mbar	(OPSO range)
Wdu	10 ÷ 115 mbar	(UPSO range)
Wrv	+10 ÷ +20% Pd	(Relief valve range)
Ac	until 10 %	(accuracy class)
Sg	until 20 %	(accuracy class)
T	-20°C ÷ 60°C	(working temperature)

Inlet connection	1" ANSI or DN-25 PN-25
Outlet connection	1" ANSI or DN-25 PN-25
Connections position	Axial
Weight SUTON 2V 2810 □1	19.0 Kg

## RELIEF VALVE

For installations ON-OFF, the output of the regulator should be sufficiently large lungs to absorb water hammer. It is recommended that lung mounted external relief valve capable of removing pressure peaks.

The quantity of gas released by pressure relief valve is related to the difference of inlet pressure and his calibrated. In the attached image is shown as an example, the relief valve VS 25 model. In which its operation is based on the confrontation of forces on both sides of the membrane.

On one side of the membrane, the gas pressure acts, on the opposite side and the spring force adjustment.

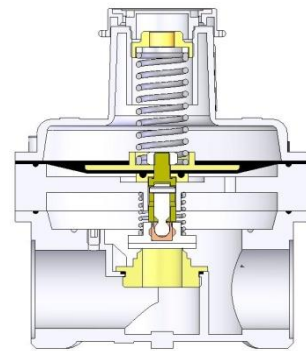

External relief valve VS-25

## MOUNTING POSITION

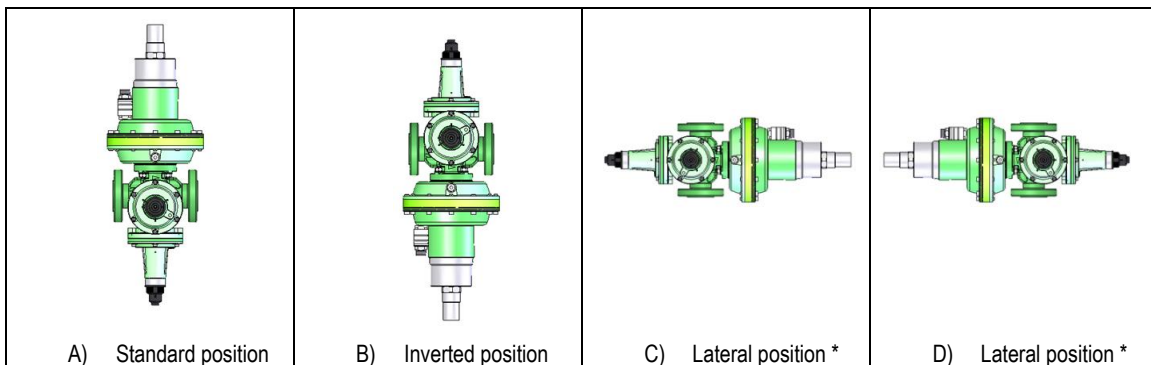



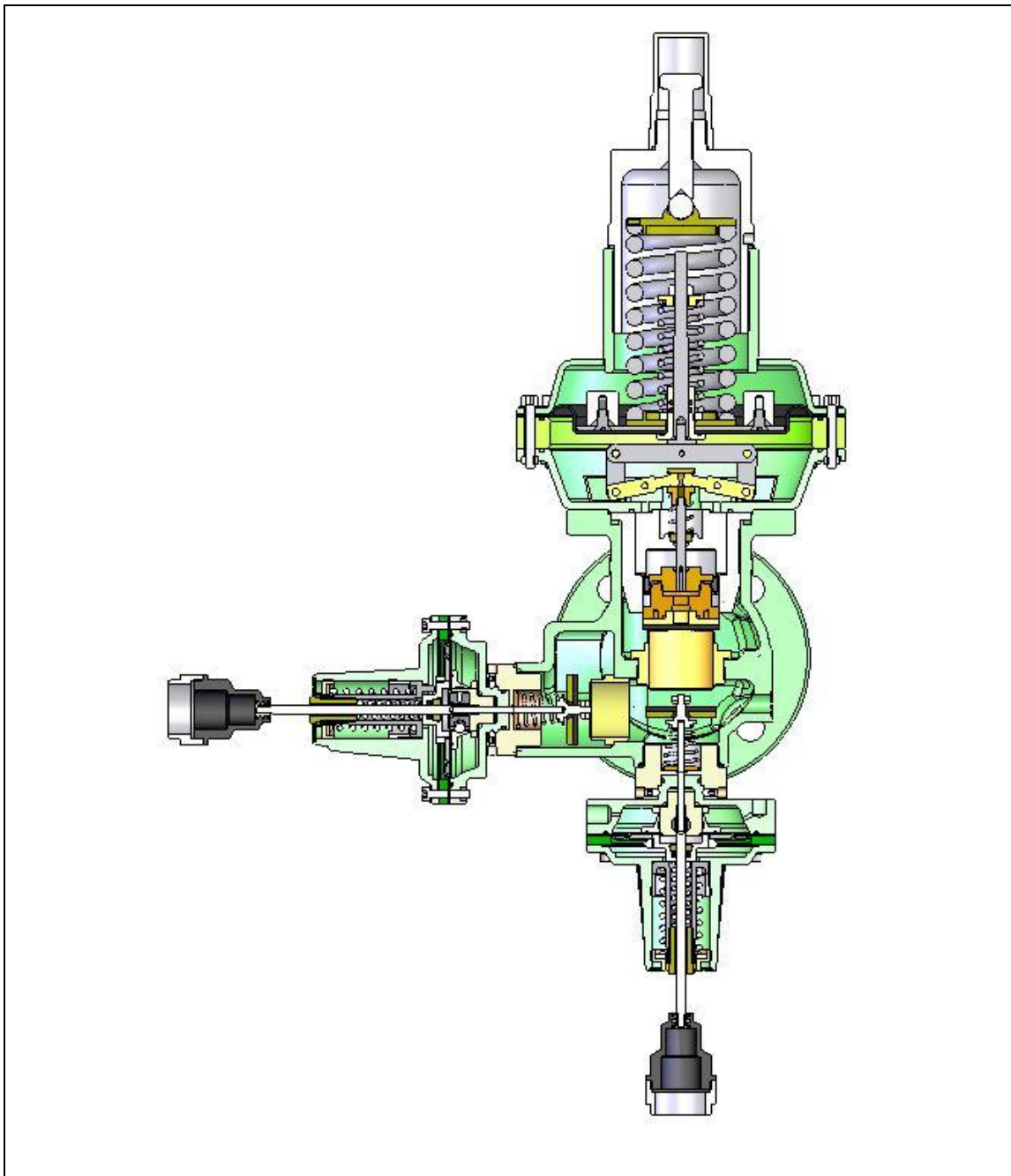

\* Lateral position inadvisable in this regulator.

For correct operation, the regulator must be mounted according to the above figures; the first image (A) is the usual position of mounting. There should be enough space for the maintenance work.

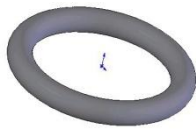
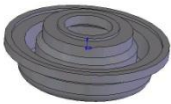

**SPARE PARTS FOR SUTON 2V 2810□1**

 <p>Obturator (O) Code ZM.1.00.2881</p>	 <p>Orifice (P) Code ZM.1.00.1541</p>	 <p>Construction O-rings</p> <table border="0"> <thead> <tr> <th>Item</th> <th>Code</th> </tr> </thead> <tbody> <tr> <td>D</td> <td>ZM.1.00.3053</td> </tr> <tr> <td>E</td> <td>ZM.1.00.1318</td> </tr> <tr> <td>F</td> <td>ZM.1.00.1224</td> </tr> <tr> <td>G</td> <td>ZM.1.00.1440</td> </tr> <tr> <td>H</td> <td>ZM.1.00.0599</td> </tr> </tbody> </table> <p>Body O-Rings</p> <table border="0"> <tbody> <tr> <td>I</td> <td>ZM.1.00.0237</td> </tr> <tr> <td>J</td> <td>ZM.1.00.2173</td> </tr> </tbody> </table>	Item	Code	D	ZM.1.00.3053	E	ZM.1.00.1318	F	ZM.1.00.1224	G	ZM.1.00.1440	H	ZM.1.00.0599	I	ZM.1.00.0237	J	ZM.1.00.2173
Item	Code																	
D	ZM.1.00.3053																	
E	ZM.1.00.1318																	
F	ZM.1.00.1224																	
G	ZM.1.00.1440																	
H	ZM.1.00.0599																	
I	ZM.1.00.0237																	
J	ZM.1.00.2173																	
 <p>Compensation Diaphragm (M) Code: ZM.1.00.0353</p>	 <p>Main Diaphragm (E) Code: ZM.1.00.06722</p>																	

## SAFETY SHUT-OFF DEVICE (SAV)

The SUTON 2V 2810 □1 regulator, is available with built-in safety valve (SAV), or can also be mounted in the future if the installation conditions vary.

In the future if you want to mount the SAV, request the set RI.ORG.0251 and instead on the cap (3)

### SAV installation

- With the Open-end spanner, loosen and remove the cap (3)
- Insert the RI.ORG.0251, threading clockwise, taking care to reassemble the O-ring (A). Tighten the neck of the SAV with the spanner hook inserted into the holes (41)
- Loosen the screws (42) with a 2.5 mm Allen key and turn the SAV to connect the pressure tubing between the fitting (43) and exit the lung.
- Tighten the screws (42) with 2.5 mm Allen key.
- Connect with 10 mm diameter tube, the fitting (43) and the lung that are located at the exit, a distance at least 5 times the diameter of the lung output, taking care not to ride in this tube, gas valves that can break up the gas.

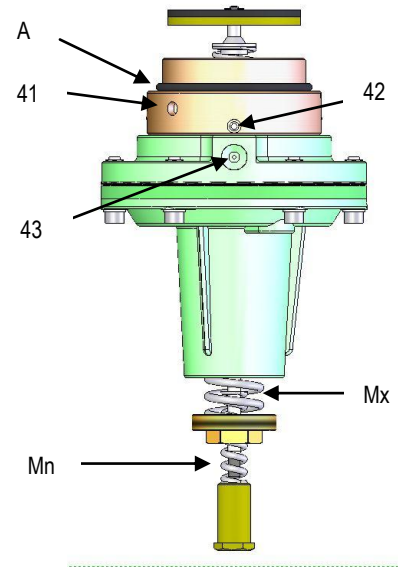

### UPS0 ADJUSTMENT SPRINGS

Spring code	Spring color	Ø Wire (mm)	Length (mm)	Ø Outside (mm)	Spring Range in kPa (mbar)
ZM.3.10.060.121	White	1.2	60	10	1.0 ÷ 3.2 (10 ÷ 32)
ZM.3.13.055.151	Yellow	1.5	55	13	2.4 ÷ 3.7 (24 ÷ 40)
ZM.3.13.055.201	Blue	2.0	55	13	3.0 ÷ 11.5 (30 ÷ 115)

### OPSO ADJUSTMENT SPRINGS

Spring code	Spring color	Ø Wire (mm)	Length (mm)	Ø Outside (mm)	Spring Range in kPa (mbar)
ZM.3.30.060.221	Silver	2.2	60	30	4.0 ÷ 13.0 (40 ÷ 130)
ZM.3.30.060.251	Green	2.5	60	30	6.0 ÷ 19.0 (60 ÷ 190)
ZM.3.30.060.271	Red	2.7	60	30	9.0 ÷ 24.0 (90 ÷ 240)

**WARNING!** It is potentially dangerous to manipulate a gas installation and its components. Therefore all start-up, adjustments and maintenance of the regulator must be carried out by duly authorized people with sufficient technical knowledge.