

APQ S.A.

www.apq.com.es
EU Product / Spain

DN 25 (1")
REGULATOR RPM 2500A3
REGULATOR RPM 2500D3

Cod. RIRPM2500A3
Cod. RIRPM2500D3

DESCRIPTION

The **RPM 2500□3** Regulator is designed for use in distribution networks with medium to high inlet pressures.

They are direct acting regulator, where the spring housing/regulator head (1) is mounted directly to the flanged body (2).

The **RPM 2510□3** versions include an optional Over-Pressure (OPSO) and/or Under-Pressure (UPSO) Shut-Off facility, which takes the place of the lower body plug (3).

MODEL

There are two models in the range, depending on the required inlet/outlet pressures.

Model MP (Medium pressure version): For outlet pressures from 10 to 40 kPa (100 to 400 mbar).
(This technical sheet)

Model AP (High pressure version): For outlet pressures from 35 to 400 kPa (350 to 4000 mbar).
(Please refer to technical datasheet RPM 2500□5)

CONNECTIONS

Model RPM 2500 A3 is with 1" ANSI-150 flanges

Model RPM 2500 D3 is with DN-25 PN-25 flanges

ASSEMBLY

- Prior to installing the regulator, please verify the pressure and connection details required correspond with the information on the label (15).
- Assure that the fluid flows in the direction that the arrow (14) indicates.
- Make the connection of the sense lines (12) to a straight pipeline, turbulence free, downstream the outlet of the regulator (at a distance of at least 5 times the diameter of the pipe). The sense line tube should have a minimum diameter of 10mm and should be totally exempted of any type of obstruction, valves and diameter reductions.
- The area of installation of the regulator should be adequate to allow maintenance labors and outlet pressure adjustments.
- The OPSO/UPSO Device (Optional) is mounted on the lower section of the regulator. It monitors the downstream pressure independently of the main section of the regulator. The OPSO/UPSO device can be ordered with the regulator, or can be fitted separately, later if required.

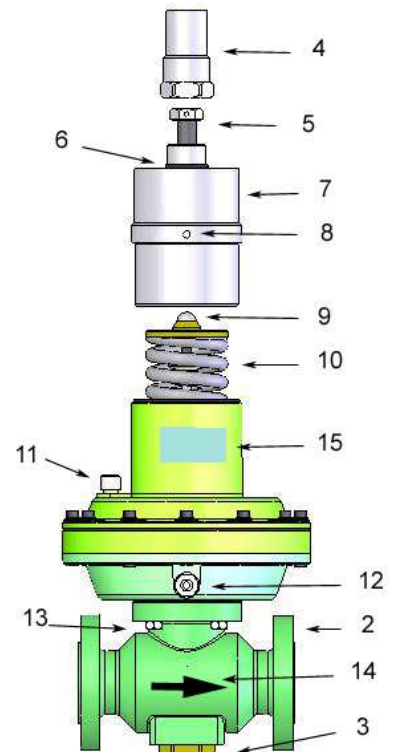
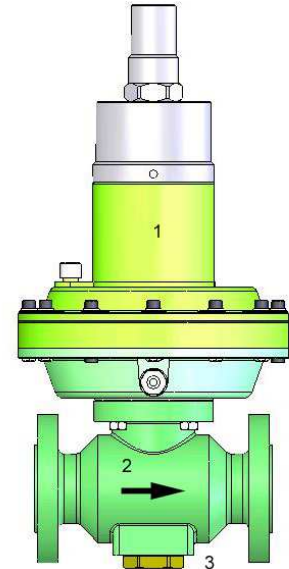

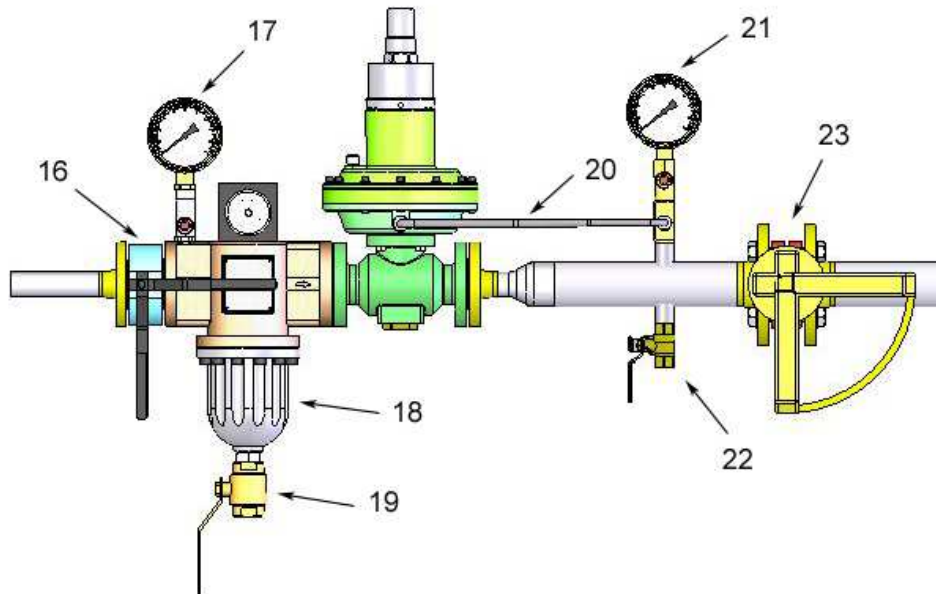

STARTUP PROCEDURE

- Open the bleed valve (22) to provide a slight flow of gas.
- Slightly and slowly, open the inlet valve (16), located immediately upstream of the regulator.
- Check that the inlet pressure (17) is correct.
- Verify that the outlet pressure (21) has stabilized.
- The main inlet valve (16), found at the inlet of the filter (18), can now be fully opened.
- Slowly open the outlet valve (23).
- If the regulator is fitted with an OPSO/UPSO, this should be kept in mind.

REGULATOR SETUP

Outlet Pressure Adjustment:

- Remove the aluminum cap (4), located on the top of the regulator (1).
- To increase outlet pressure, turn the main spring adjustment bolt (5) CLOCKWISE with a Tube Spanner 24mm.
- Turning this bolt anti-clockwise will decrease the outlet pressure.
- Place the cap (4) back onto the regulator top, make sure to put the O-ring (6).

The spring used in these regulators (10) have been designed to provide specific outlet pressure ranges. For outlet pressures outside the specified range, a spring change will be required.

Causes of abnormal operation:

- Sense lines (20) -optional-, not connected, blocked or leaking.
- Sense lines (20) -optional- may be of insufficient diameter, or connected at a location of turbulence in the pipeline.
- Pressure required is outside the range of the spring installed.
- Flow capacity requires exceeds regulator capacity.
- Atmospheric Vent (11) blocked or restricted.

If regulator does not close perfectly, this may be caused by:

- A worn, damaged, or pitted Valve Seat Disc (O).
- Orifice may be worn (P).
- O-ring may be worn.
- Deterioration of the main diaphragm.

If the OPSO/UPSO does not close perfectly:

- Please refer to the Technical Data Sheet relevant to the OPSO/UPSO device concerned.

To avoid particle damage of the internal working parts of the regulator, it is necessary to install a filter (18) of not less than 50 microns prior to the regulator.

CHANGING THE MAIN SPRING:

Removing the main spring:

- Close inlet valve (16) and the outlet valve (23).
- Depressurize the inlet and outlet side of the regulator via purge valves 19 and 22.
- Remove main regulator cap (4) to access the bolt (5).
- Turn the adjustment bolt (5) ANTI-CLOCKWISE, until all pressures is taken off the main spring.
- Using a 90 to 155mm hook-spanner, turn the main spring housing (7) anti-clockwise to reveal the main spring.
- Extract the spring.

Re-assembly:

- Insert the spring of appropriate outlet pressure range.
- Re-assemble the main spring housing in reverse order to the above instructions.
- **Please ensure only spring of appropriate size are fitted, and the spring plate and ball-bearing (9) are relocated on the top of the replacement spring, as failure to do so may cause regulator damage or failure.**







REMOVAL OF THE MOBILE DEVICE:

- Close inlet Valve (16) and outlet Valve (23).
- Depressurize the inlet and outlet side of the regulator via purge valves 19 and 22.
- Disconnect the sense line (20) connected to the underside of the main diaphragm housing (12).
- Using a 13mm spanner, loosen and remove the four nuts (13).
- The regulator head can now be safely removed.

Re-assembly

- To re-fit the regulator head, reverse the above procedure.

TOOLS REQUIRED FOR THE MAINTAINANCE OF THE RPM 2500□3 REGULATORS

			
Hook-Spanner 90-155mm	O-ring Extractor	Allen Key 4 - 5 mm	Tube Spanner 13 - 24 - 30 mm
			
Open-end Spanner 13 - 19 - 27 mm	Screwdriver 10 x 1,6 mm	Tweezers	

OUTLET PRESSURE ADJUSTMENT SPRINGS FOR THE DBM 2500□3 REGULATORS

Spring Code	Spring Color	Ø Wire (mm)	Length (mm)	Ø Outside (mm)	n° Turns	Spring Range in kPa (mbar)
ZM370155070A	Zinc + yellow stripe	7	155	70	9.5	10 ÷ 22 (100 ÷ 220)
ZM370155080A	Zinc + blue stripe	8	155	70	9.5	20 ÷ 34 (200 ÷ 340)
ZM373155090A	Zinc + black stripe	9	155	73	8.5	25 ÷ 50 (250 ÷ 500)

FLOW

Flow regulator (n)m³/h natural gas with sense line (20) connected. Flow with different orifices.

The regulator should work within the range indicated in the tables, with the maximum inlet pressure, the resulting variable output pressure and the orifice attached, these must not be exceeded the limits described in the table.

The speed of the gas flowing through the outlet pipe where the pressure is taken to drive the regulator (20) and Shut-off valve must be less than 12 m/sec.

The accuracy class is AC20 / SG30

RPM 2500 □3 Orifice Ø 4 mm

P _a (bar)	P _e (bar)															
	1.0	1.5	2.0	2.5	3.0	4.0	5.0	6.0	8.0	10.0	12.0	15.0	18.0	20.0	22.0	25.0
0.1	21	29	34	40	46	57	69	74	74	74	74	74	74	74	74	74
0.15	20	29	34	40	46	57	69	77	77	77	77	77	77	77	77	77
0.2	20	29	34	40	46	57	69	80	81	81	81	81	81	81	81	81
0.25	19	29	34	40	46	57	69	80	84	84	84	84	84	84	84	84
0.3	19	26	34	40	46	57	69	80	87	87	87	87	87	87	87	87
0.35	19	26	34	40	46	57	69	80	91	91	91	91	91	91	91	91
0.40	18	25	34	40	46	57	69	80	94	94	94	94	94	94	94	94

L RPM 2500 □3 Orifice Ø 6 mm

P _a (bar)	P _e (bar)															
	1.0	1.5	2.0	2.5	3.0	4.0	5.0	6.0	8.0	10.0	12.0	15.0	18.0	20.0	22.0	25.0
0.1	39	55	66	74	74	74	74	74	74	74	74	74	74	74		
0.15	39	55	66	76	77	77	77	77	77	77	77	77	77	77		
0.2	38	55	66	76	81	81	81	81	81	81	81	81	81	81	81	81
0.25	37	55	66	76	84	84	84	84	84	84	84	84	84	84	84	84
0.3	36	50	66	76	87	87	87	87	87	87	87	87	87	87	87	87
0.35	35	49	66	76	87	91	91	91	91	91	91	91	91	91	91	91
0.40	34	49	66	76	87	94	94	94	94	94	94	94	94	94	94	94

RPM 2500 □3 Orifice Ø 8 mm

P _a (bar)	P _e (bar)															
	1.0	1.5	2.0	2.5	3.0	4.0	5.0	6.0	8.0	10.0	12.0	15.0	18.0	20.0	22.0	25.0
0.1	67	74	74	74	74	74	74	74								
0.15	66	77	77	77	77	77	77	77	77	77						
0.2	65	81	81	81	81	81	81	81	81	81	81					
0.25	64	84	84	84	84	84	84	84	84	84	84	84				
0.3	62	85	87	87	87	87	87	87	87	87	87	87	87	87		
0.35	61	84	91	91	91	91	91	91	91	91	91	91	91	91	91	
0.40	59	83	94	94	94	94	94	94	94	94	94	94	94	94	94	94

RPM 2500 □3 Orifice Ø 10 mm

P _a (bar)	P _e (bar)															
	1.0	1.5	2.0	2.5	3.0	4.0	5.0	6.0	8.0	10.0	12.0	15.0	18.0	20.0	22.0	25.0
0.1	74	74	74	74	74	74										
0.15	77	77	77	77	77	77	77	77								
0.2	76	81	81	81	81	81	81	81	81							
0.25	74	84	84	84	84	84	84	84	84	84						
0.3	73	87	87	87	87	87	87	87	87	87	87					
0.35	71	91	91	91	91	91	91	91	91	91	91	91				
0.40	80	94	94	94	94	94	94	94	94	94	94	94				

RPM 2500 □3 Orifice Ø 12 mm

P _a (bar)	P _e (bar)															
	1.0	1.5	2.0	2.5	3.0	4.0	5.0	6.0	8.0	10.0	12.0	15.0	18.0	20.0	22.0	25.0
0.1	74	74	74													
0.15	77	77	77	77	77	77										
0.2	81	81	81	81	81	81	81									
0.25	84	84	84	84	84	84	84	84								
0.3	85	87	87	87	87	87	87	87	87							
0.35	83	91	91	91	91	91	91	91	91	91						
0.40	80	94	94	94	94	94	94	94	94	94	94					

Flow in (n)m³/h natural gas

Flow with other gases

In the tables above, the flow is in (n)m³/h natural gas with a density 0.61 and temperature 15° C

To convert to other gas flow, using the following formula:

$$Q \text{ (n)m}^3/\text{h natural gas} \times F_c = Q \text{ (n)m}^3/\text{h n gas}$$

Example:

$$Q \text{ (n)m}^3/\text{h natural gas} \times 0.78 = Q \text{ (n)m}^3/\text{h air}$$

$$1 \text{ (n)m}^3/\text{h natural gas} = 0.78 \text{ (n)m}^3/\text{h air}$$

Correction factor Fc a 15°C	
Butane	0.55
Propane	0.64
Oxygen	0.76
Air	0.78
Nitrogen	0.81
Biogas	0.85
Town gas	1.23
Hydrogen	3.04

ADJUSTING RPM-2500 □3 FORMED BY REGULATOR + EXTERNAL RELIEF VALVE + OPSO AND UPSO			
Outlet pressure Pa	Setting relief valve	Setting OPSO	Setting UPSO
100 ÷ 400 mbar	> Pa x 1.3	> Pa x 1.5	< Pa x 0.6

DIMENSIONS AND WEIGHTS

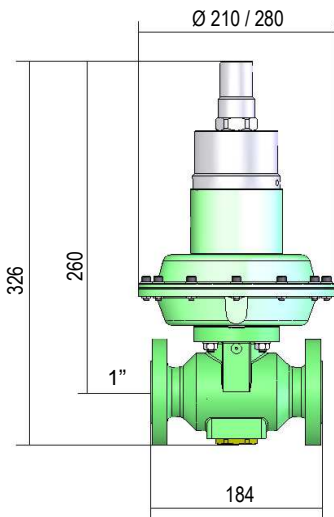

2500 □3

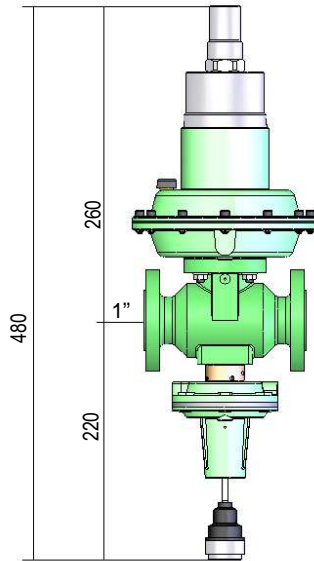

2510 □3

Technical features of RPM 2500 □3

bpu	0.2 ÷ 25 bar	(inlet pressure range)
Ps	25 bar	(design pressure)
Pu	25 bar	(maximum inlet pressure)
Wd		(outlet pressure range)
RPM 2500 □3	100 ÷ 400 mbar	
Wdo	180 ÷ 800 mbar	(OPSO range)
Wdu	35 ÷ 400 mbar	(UPS0 range)
Ac	until 10 %	(accuracy class)
Sg	until 20 %	(accuracy class)
T	-20°C ÷ 60°C	(working temperature)

Inlet connection	1" ANSI or DN-25 PN-25
Outlet connection	1" ANSI or DN-25 PN-25
Connections position	Axial
Weight RPM-2500 □3	9.0 Kg
Weight RPM-2510 □3	10.0 Kg

RELIEF VALVE

For installations ON-OFF, the output of the regulator should be sufficiently large lungs to absorb water hammer. It is recommended that lung mounted external relief valve capable of removing pressure peaks.

The quantity of gas released by pressure relief valve is related to the difference of inlet pressure and his calibrated. In the attached image is shown as an example, the relief valve VS 25 model. In which its operation is based on the confrontation of forces on both sides of the membrane.

On one side of the membrane, the gas pressure acts, on the opposite side and the spring force adjustment.

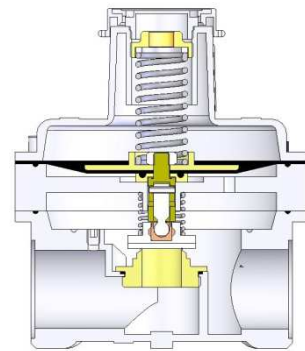

External relief valve VS-25

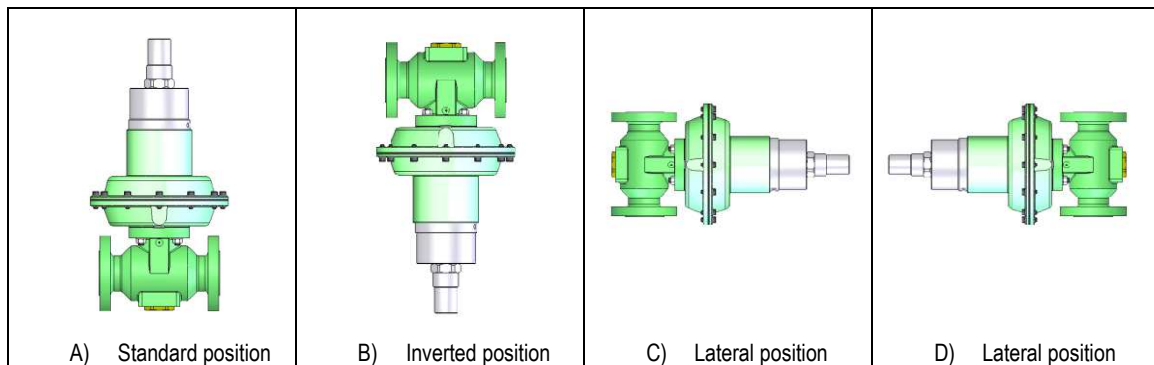

MOUNTING POSITION

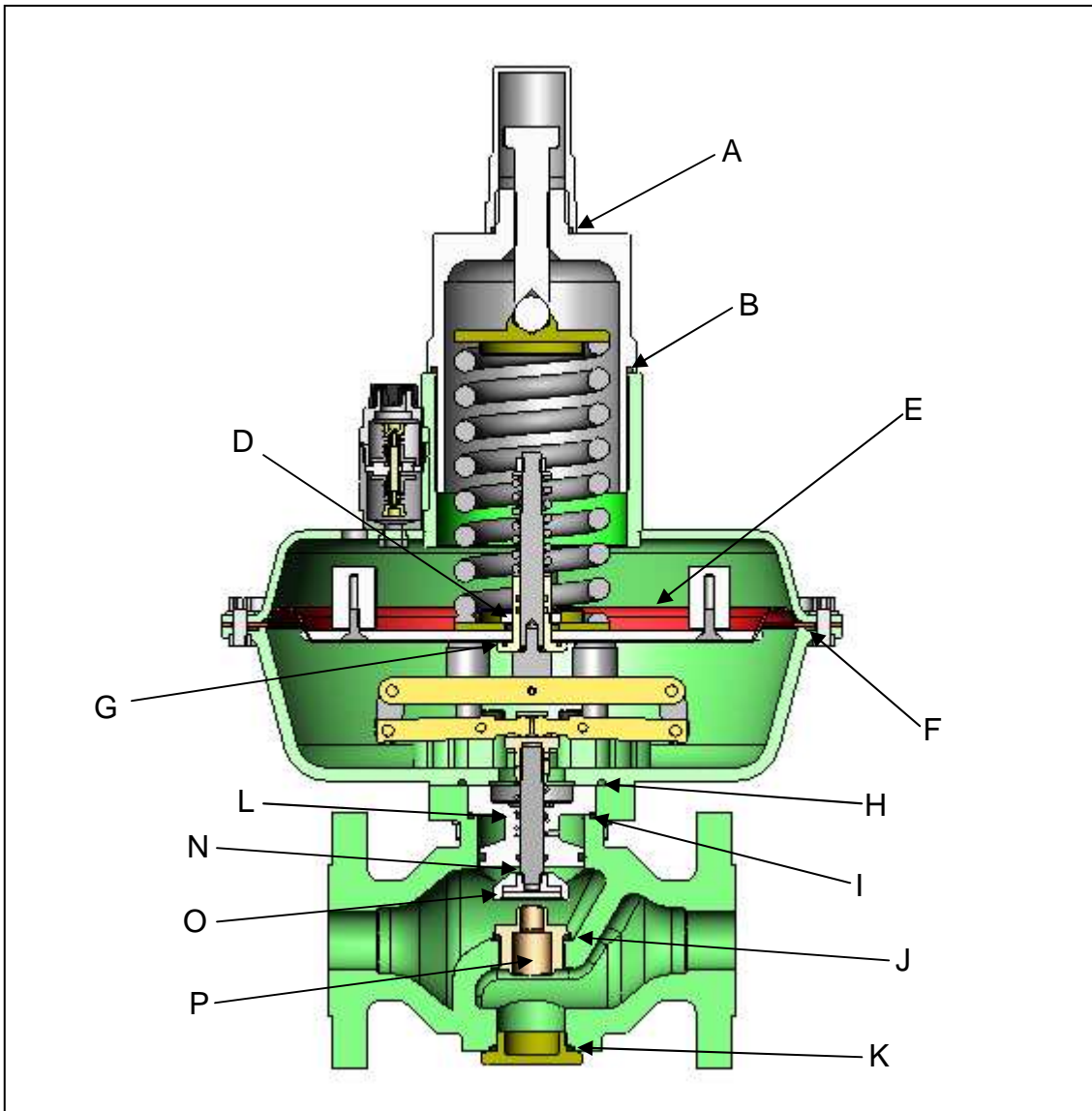

For correct operation, the regulator must be mounted according to the above figures; the first image (A) is the usual position of mounting. There should be enough space for the maintenance work.

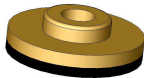

SPARE PARTS FOR ORDINARY MAINTENANCE OF THE RPM 2500 □3

 <p>Orifice (P)</p> <table border="1"> <thead> <tr> <th>Ø</th> <th>Code</th> </tr> </thead> <tbody> <tr> <td>4</td> <td>ZM.1.00.2285</td> </tr> <tr> <td>6</td> <td>ZM.1.00.2286</td> </tr> <tr> <td>8</td> <td>ZM.1.00.2287</td> </tr> <tr> <td>10</td> <td>ZM.1.00.2288</td> </tr> <tr> <td>12</td> <td>ZM.1.00.2289</td> </tr> </tbody> </table>	Ø	Code	4	ZM.1.00.2285	6	ZM.1.00.2286	8	ZM.1.00.2287	10	ZM.1.00.2288	12	ZM.1.00.2289	 <p>Obturator (O) Code ZM.1.00.070615</p>  <p>Main Diaphragm (E) Code ZM.1.00.2191A</p>	 <p>O-rings in the regulator</p> <table border="1"> <thead> <tr> <th>Position</th> <th>Code</th> </tr> </thead> <tbody> <tr> <td>A</td> <td>ZM.1.00.0843</td> </tr> <tr> <td>B</td> <td>ZM.1.00.1428</td> </tr> <tr> <td>D</td> <td>ZM.1.00.0974</td> </tr> <tr> <td>F</td> <td>ZM.1.00.3159</td> </tr> <tr> <td>G</td> <td>ZM.1.00.0893</td> </tr> <tr> <td>H</td> <td>ZM.1.00.0509</td> </tr> <tr> <td>L</td> <td>ZM.1.00.0974V</td> </tr> <tr> <td>N</td> <td>ZM.1.00.1355</td> </tr> </tbody> </table> <p>O-rings in the valve body</p> <table border="1"> <tbody> <tr> <td>I</td> <td>ZM.1.00.2173</td> </tr> <tr> <td>J</td> <td>ZM.1.00.1346</td> </tr> <tr> <td>K</td> <td>ZM.1.00.1467</td> </tr> </tbody> </table>	Position	Code	A	ZM.1.00.0843	B	ZM.1.00.1428	D	ZM.1.00.0974	F	ZM.1.00.3159	G	ZM.1.00.0893	H	ZM.1.00.0509	L	ZM.1.00.0974V	N	ZM.1.00.1355	I	ZM.1.00.2173	J	ZM.1.00.1346	K	ZM.1.00.1467
Ø	Code																																					
4	ZM.1.00.2285																																					
6	ZM.1.00.2286																																					
8	ZM.1.00.2287																																					
10	ZM.1.00.2288																																					
12	ZM.1.00.2289																																					
Position	Code																																					
A	ZM.1.00.0843																																					
B	ZM.1.00.1428																																					
D	ZM.1.00.0974																																					
F	ZM.1.00.3159																																					
G	ZM.1.00.0893																																					
H	ZM.1.00.0509																																					
L	ZM.1.00.0974V																																					
N	ZM.1.00.1355																																					
I	ZM.1.00.2173																																					
J	ZM.1.00.1346																																					
K	ZM.1.00.1467																																					

SAFETY SHUT-OFF DEVICE (SAV)

The RPM 2500 □3 regulator, is available with built-in safety valve (SAV), or can also be mounted in the future if the installation conditions vary.

In the future if you want to mount the SAV, request the set RI.ORG.0252 and instead on the cap (3)

SAV installation

- With the Open-end spanner, loosen and remove the cap (3)
- Insert the RI.ORG.0252, threading clockwise, taking care to reassemble the O-ring (A). Tighten the neck of the SAV with the spanner hook inserted into the holes (41)
- Loosen the screws (42) with a 2.5 mm Allen key and turn the SAV to connect the pressure tubing between the fitting (43) and exit the lung.
- Tighten the screws (42) with 2.5 mm Allen key.
- Connect with 10 mm diameter tube, the fitting (43) and the lung that are located at the exit, a distance at least 5 times the diameter of the lung output, taking care not to ride in this tube, gas valves that can break up the gas.

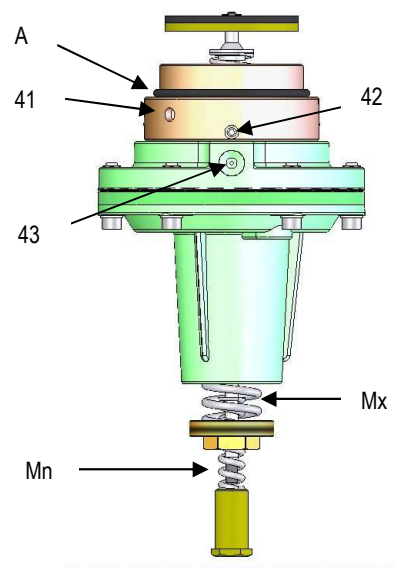

UPSO ADJUSTMENT SPRINGS

Spring code	Spring color	Ø Wire (mm)	Length (mm)	Ø Outside (mm)	Spring Range in kPa (mbar)
ZM.3.12.055201	Blue	2.0	55	12.3	3.5 ÷ 11 (35 ÷ 110)
ZM.3.12.055231	Black	2.3	55	12.3	5 ÷ 25 (50 ÷ 250)
ZM.3.12.055251	Purple	2.5	55	12.3	8 ÷ 40 (80 ÷ 400)

OPSO ADJUSTMENT SPRINGS

Spring code	Spring color	Ø Wire (mm)	Length (mm)	Ø Outside (mm)	Spring Range in kPa (mbar)
ZM.3.30.060251	Green	2.5	60	30	18 ÷ 29 (180 ÷ 290)
ZM.3.30.060271	Red	2.7	60	30	23 ÷ 37 (230 ÷ 370)
ZM.3.30.060321	Yellow	3.2	60	30	30 ÷ 50 (300 ÷ 500)
ZM.3.30.060351	Blue	3.5	60	30	40 ÷ 80 (400 ÷ 800)

WARNING! It is potentially dangerous to manipulate a gas installation and its components. Therefore all start-up, adjustments and maintenance of the regulator must be carried out by duly authorized people with sufficient technical knowledge.