

Eclipse RatioMatic

Burners

Model RM0300

Version 5

Parameter	Specification		
	Chamber Pressure "w.c. (mbar)	50 Hz	60 Hz
Blower Type			
Maximum Input, Btu/h (kW)¹	-5.0 (-12.4)	3,500,000 (1020)	3,550,000 (1040)
<i>Contact factory for chamber pressures outside the given range, or varying chamber pressure conditions.</i>	-2.0 (-5.0)	3,170,000 (920)	3,220,000 (940)
	0 (0.0)	2,950,000 (860)	3,000,000 (880)
	2.0 (5.0)	2,690,000 (780)	2,740,000 (800)
	5.0 (12.4)	2,250,000 (660)	2,300,000 (670)
	Minimum Input On-Ratio, Btu/h (kW) <i>Lower inputs may be achieved. Contact factory.</i>	65,000 (19)	
Main Gas Inlet Pressure, "w.c. (mbar)² <i>Fuel pressure at ratio regulator inlet</i>	Natural Gas	20 to 55 (50 to 140)	
	Propane/Butane	20 to 35 (50 to 90)	
High Fire Flame Length, inches (mm) <i>Measured from the outlet end of the combustor</i>	Natural Gas	60 (1524)	
	Propane/Butane	65 (1650)	
Maximum Chamber Temperature, °F (°C)	Alloy Tube	1500 (815)	
	Block and Holder	1900 (1038)	
Flame Detection	Alloy Tube	Flamerod or UV Scanner	
	Block and Holder	UV scanner only	
Fuel <i>For any other mixed gas, contact Eclipse, Inc.</i>	Natural Gas, Propane, Butane ³		
Blower Motor Power, Hp	1.5		
Weight, lbs (kg)⁴	Alloy Tube	90 (41)	
	Refractory	214 (97)	
Approvals			

¹ Maximum inputs for packaged blower versions are given for the standard combustion air blower without an inlet air filter.

² For proper performance, this pressure must be kept constant across the burner operating range.

³ See Design Guide 110 for more information about typical fuel composition and properties.

⁴ All weights are approximate.

- All information is based on laboratory testing. Different chamber conditions will affect the data.
- All inputs based upon gross calorific values and standard conditions; 1 atmosphere, 70°F (21°C).
- Eclipse reserves the right to change the construction and/or configuration of our products at any time without being obliged to adjust earlier supplies accordingly.

Performance Graphs

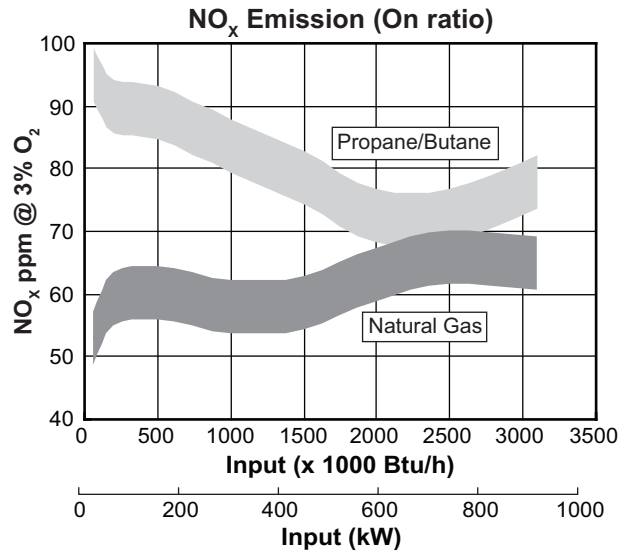
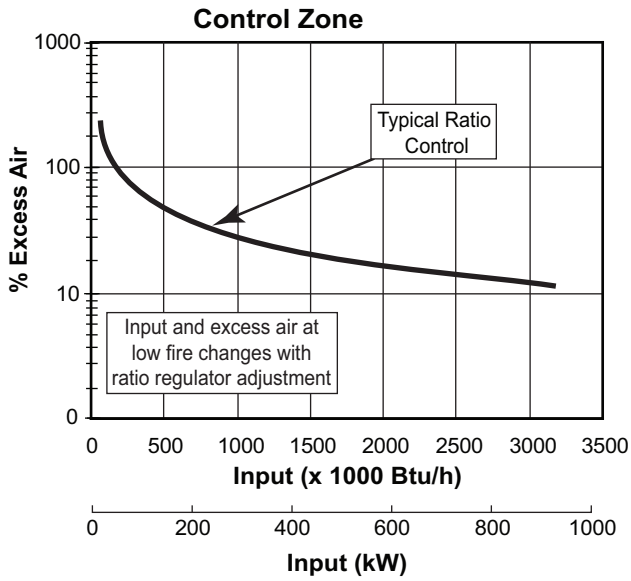

NO_x Emission data is given for:

- Ambient combustion air ~70°F (21°C)
- Less than 700°F (370°C) firing chamber
- Minimal process air velocity
- Low fire input adjusted to 40,000 Btu/h (12 kW)
- ppm volume, dry @ 3% O₂
- Neutral chamber pressure

Emissions from the burner are influenced by:

- Chamber conditions
- Fuel type
- Firing rate
- Ratio regulator adjustment
- Combustion air temperature

CO emission is largely influenced by chamber conditions. Contact your local Eclipse representative for an estimate of CO emission on your application

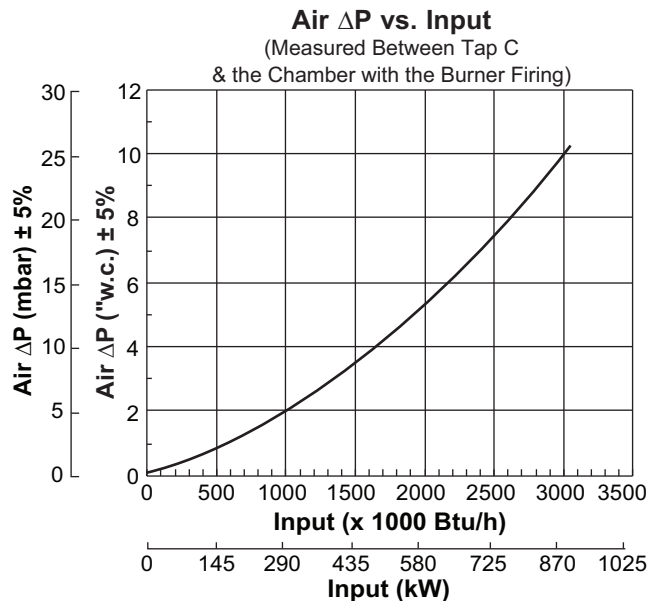
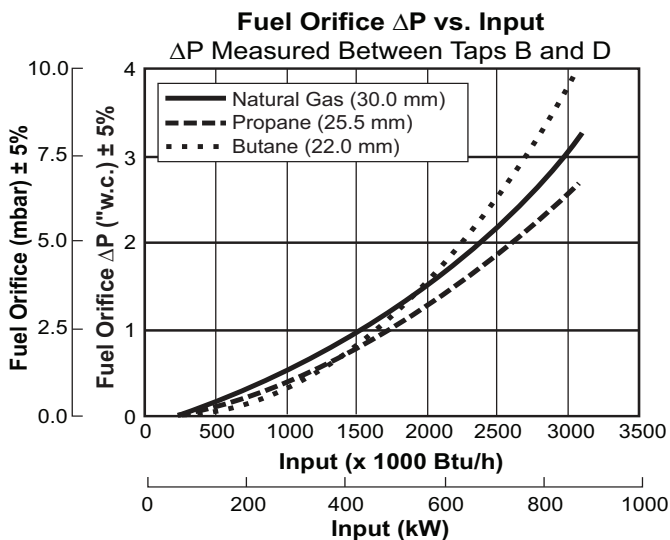

Dimensions & Specifications

Dimensions in mm (in)

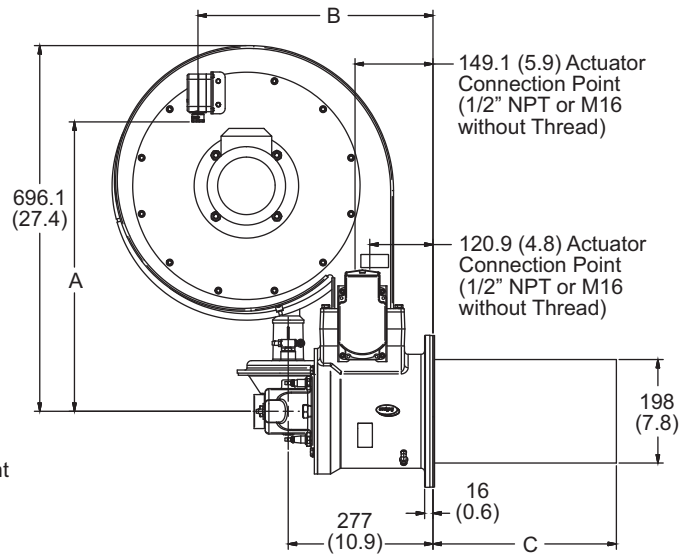
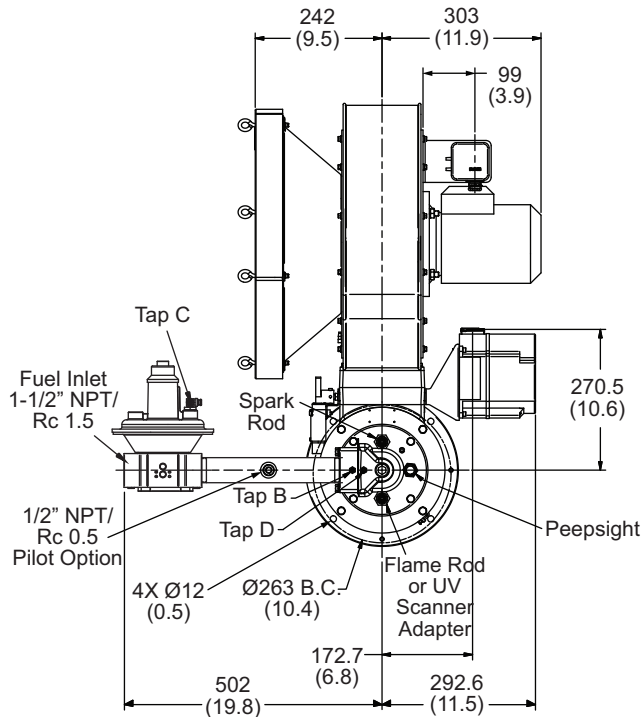

Shown with Alloy Combustor

Blower Size	A	B
50 Hz	533 (21)	394 (15.5)
60 Hz	488 (19.2)	363 (14.3)

Combustor Type	C
Straight Stainless Steel Alloy Tube	351 (13.8)
Straight Stainless Steel Alloy Tube	427 (16.8)

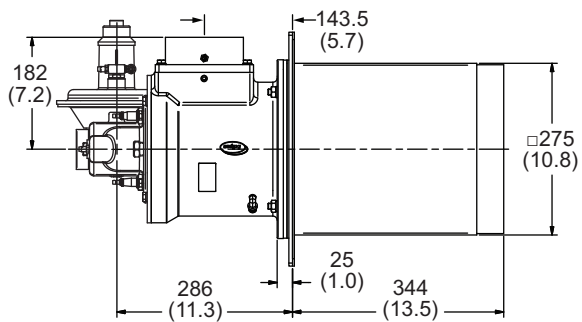
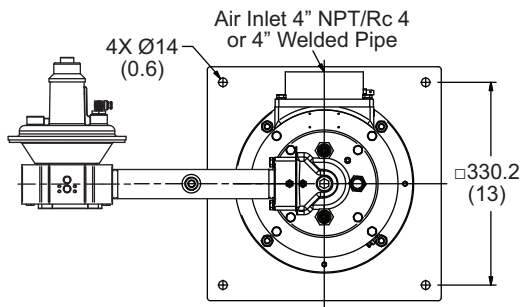

Square Block and Holder

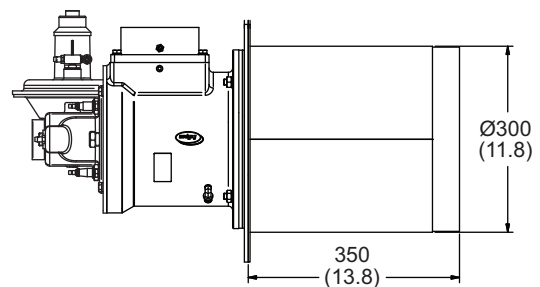
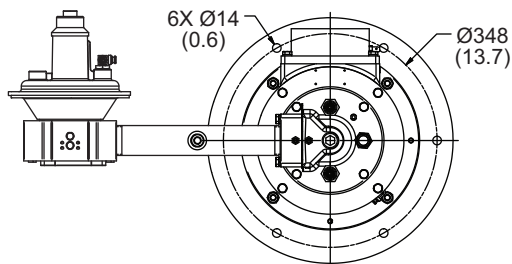

Round Block and Holder

Combustor Options

Alloy Tube

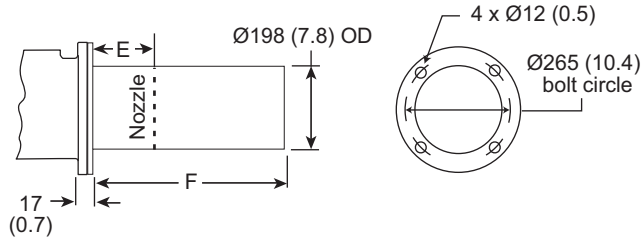

E	F
154 (6.1)	350 (13.8)
230 (9.1)	426 (16.8)

Square Block & Holder

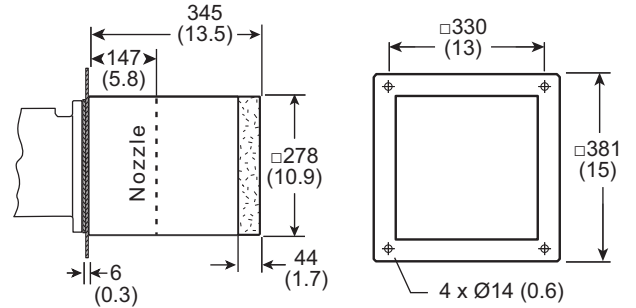

Round Block & Holder

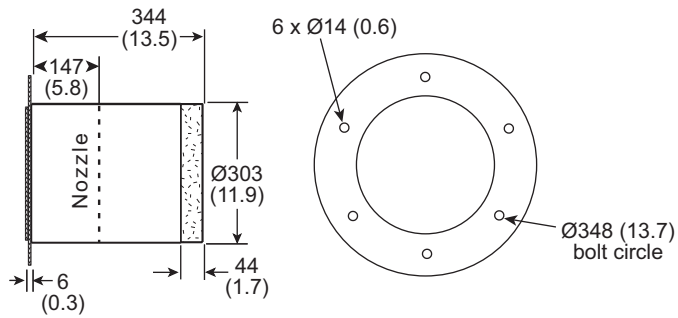

Burner Configuration

