

# Eclipse AirHeat

# Burners

AH-MA Series

Version 2

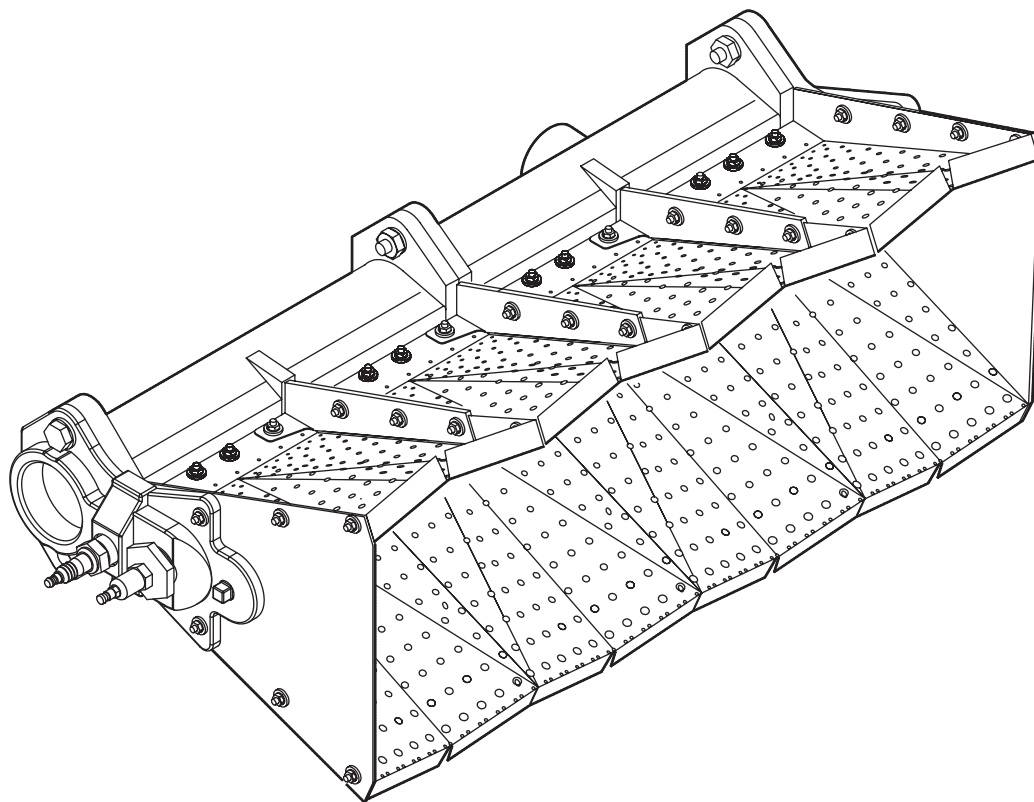

## **Copyright**

Copyright 2007 by Eclipse, Inc. All rights reserved worldwide. This publication is protected by federal regulation and shall not be copied, distributed, transmitted, transcribed or translated into any human or computer language, in any form or by any means, to any third parties, without the express written consent of Eclipse, Inc.

## **Disclaimer Notice**

In accordance with the manufacture's policy of continual product improvement, the product presented in this brochure is subject to change without notice or obligation.

The material in this manual is believed adequate for the intended use of the product. If the product is used for purposes other than those specified herein, confirmation of validity and suitability must be obtained. Eclipse warrants that the product itself does not infringe upon any United States patents. No further warranty is expressed or implied.

## **Liability & Warranty**

We have made every effort to make this manual as accurate and complete as possible. Should you find errors or omissions, please bring them to our attention so that we may correct them. In this way we hope to improve our product documentation for the benefit of our customers. Please send your corrections and comments to our Marketing Communications Manager.

It must be understood that Eclipse's liability for its product, whether due to breach of warranty, negligence, strict liability, or otherwise is limited to the furnishing of replacement parts and Eclipse will not be liable for any

other injury, loss, damage or expenses, whether direct or consequential, including but not limited to loss of use, income, or damage to material arising in connection with the sale, installation, use of, inability to use, or the repair or replacement of Eclipse's products.

Any operation expressly prohibited in this manual, any adjustment, or assembly procedures not recommended or authorized in these instructions shall void the warranty.

## **Document Conventions**

There are several special symbols in this document. You must know their meaning and importance.

The explanation of these symbols follows below. Please read it thoroughly.

## **How To Get Help**

If you need help, contact your local Eclipse representative. You can also contact Eclipse at:

1665 Elmwood Rd.  
Rockford, Illinois 61103 U.S.A.  
Phone: 815-877-3031  
Fax: 815-877-3336  
<http://www.eclipsenet.com>

Please have the information on the product label available when contacting the factory so we may better serve you.

**ECLIPSE®** [www.eclipsenet.com](http://www.eclipsenet.com)  
Product Name  
Item #  
S/N  
DD MMM YYYY



This is the safety alert symbol. It is used to alert you to potential personal injury hazards. Obey all safety messages that follow this symbol to avoid possible injury or death.



Indicates a hazardous situation which, if not avoided, will result in death or serious injury.



Indicates a hazardous situation which, if not avoided, could result in death or serious injury.



Indicates a hazardous situation which, if not avoided, could result in minor or moderate injury.

**NOTICE**

Is used to address practices not related to personal injury.

**NOTE**

Indicates an important part of text. Read thoroughly.



# Table of Contents

<b>1 Introduction</b> .....	<b>4</b>
Product Description .....	4
Audience .....	4
Purpose .....	4
Related Documents.....	4
<b>2 Safety</b> .....	<b>5</b>
Introduction .....	5
Safety Warnings .....	5
Capabilities.....	5
Operator Training .....	5
Replacement Parts.....	5
<b>3 Installation</b> .....	<b>6</b>
Introduction .....	6
Handling & Storage .....	6
Position of Components .....	6
Approval of Components.....	6
Checklist Before Installation .....	7
Duct Configuration.....	7
Suspending the Burner.....	7
Prepare the Burner.....	8
Piping .....	9
Checklist After Installation .....	10
<b>4 Adjustment, Start &amp; Stop</b> .....	<b>11</b>
Introduction .....	11
Adjustment Procedure.....	11
Step 1: Reset the System.....	11
Step 2: Set Air Pressure Drop .....	11
Step 3: Verify the Air Setting .....	11
Step 4: Ignite Pilot .....	11
Step 5: Ignite the Burner .....	12
Step 6: Adjust Low Fire Gas.....	12
Step 7: Adjust High Fire Gas.....	12
Step 8: Verify Gas Settings .....	12
Start Procedure .....	12
Stop Procedure .....	13
<b>5 Maintenance &amp; Troubleshooting</b> .....	<b>14</b>
Introduction .....	14
Maintenance.....	14
Monthly Checklist .....	14
Yearly Checklist.....	14
Troubleshooting Guide .....	15
Parts Lists.....	17
<b>Appendix</b> .....	<b>i</b>
Conversion Factors .....	i
System Summary .....	ii

# Introduction

1

## Product Description

Eclipse AH-MA Air Heat burners produce a uniform, odorless, and smokeless flame ideal for heating fresh air in make-up and process air heating applications. The AH-MA design provides stable operation over a wide range of velocities, inputs, and fuels.

AH-MA burners are line type burners constructed of cast iron or aluminum burner bodies and diverging stainless steel air wings. The burner bodies supply fuel to the center of the air wings to control the air and fuel mixture inside the burner and to optimize emissions and efficiency. Completely corrosion resistant design options are available using aluminum burner bodies or electroless nickel plated cast iron burner bodies.

The AH-MA Air Heat burner is assembled from straight sections, tees, and crosses to produce nearly any configuration required. Large burners can be built as a combination of staged, individually controlled sections to increase turndown.

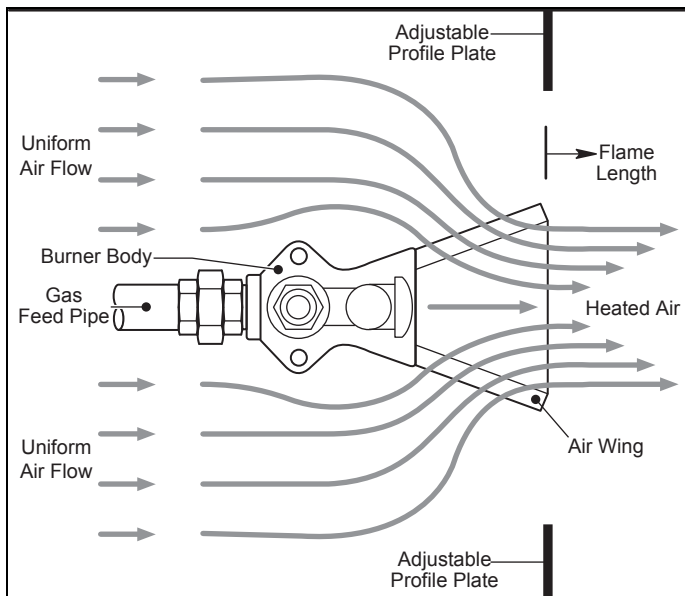

Figure 1.1. AH-MA AirHeat Burner

## Audience

This manual has been written for personnel already familiar with all aspects of an air heat burner and its add-on components, also referred to as the burner package.

These aspects are:

- Installation
- Use
- Maintenance
- Safety

The audience is expected to be qualified and have experience with this type of equipment and its working environment.

## Purpose

The purpose of this manual is to make sure that you carry out the installation of a safe, effective and trouble-free system.

## AH-MA Documents

### **Installation Guide No. 160**

- This document

### **Datasheet Series No. 160**

- Required to complete installation

### **Design Guide No. 210**

- Used with Datasheet to complete design calculations

## Related Documents

- EFE 825 (Combustion Engineering Guide)
- Eclipse Bulletins and Information Guides: 818, 820, 826, 832, 852, 854, 856

# Safety

## Introduction

Important notices for safe operation of the burner system will be found in this section. To avoid personal injury, damage to property or the facility, the following warnings must be observed. Read this entire manual before attempting to start the system. If any part of the information in this manual is not understood, contact Eclipse before continuing.

## Safety Warnings

### **DANGER**

- The burners covered by this guide are designed to mix gas with air and burn the resulting mixture. All gas burning devices are capable of producing fires and explosions if improperly applied, installed, adjusted, controlled or maintained.
- Do not bypass any safety feature; fire or explosion could result.
- Never try to light a burner if it shows signs of damage or malfunction.

### **WARNING**

- The burner and duct sections are likely to have HOT surfaces. Always wear protective clothing when approaching the burner.
- Eclipse products are designed to minimize the use of materials that contain crystalline silica. Examples of these chemicals are: respirable crystalline silica from bricks, cement or other masonry products and respirable refractory ceramic fibers from insulating blankets, boards, or gaskets. Despite these efforts, dust created by sanding, sawing, grinding, cutting and other construction activities could release crystalline silica. Crystalline silica is known to cause cancer, and health risks from the exposure to these chemicals vary depending on the frequency and length of exposure to these chemicals. To reduce the risk, limit exposure to these chemicals, work in a well-ventilated area and wear approved personal protective safety equipment for these chemicals.

### **NOTICE**

- This manual provides information in the use of the burner for its specific design purpose. Do not deviate from any instructions or application limits described herein without written advice from Eclipse.

## Capabilities

Only qualified personnel, with good mechanical aptitude and experience with combustion equipment, should adjust, maintain or troubleshoot any mechanical or electrical part of this system.

## Operator Training

The best safety precaution is an alert and trained operator. Train new operators thoroughly and have them demonstrate an adequate understanding of the equipment and its operation. A regular retraining schedule should be administered to ensure operators maintain a high degree of proficiency.

## Replacement Parts

Order replacement parts from Eclipse only. Any customer supplied valves or switches should carry UL, FM, CSA, CGA and/or CE approvals where applicable.

# Installation

# 3

## Introduction

In this section you will find the information and instructions needed to install the burner and system components.

**NOTE:** Information in Datasheet 160 is necessary to complete some of the procedures.

### **NOTICE**

- Only qualified competent personnel with experience of combustion systems are allowed to install, adjust or maintain the burner.
- All installation work must be carried out in compliance with current legislated standards.

## Handling & Storage

### **Handling**

- Make sure the area is clean.
- Inspect the burner, ensure that all components are clean and free from damage.
- Use appropriate support and handling equipment when lifting the burner.
- Protect the burner from weather, damage, dirt and moisture.
- Protect the burner and components from excessive temperatures and humidity.

### **Storage**

- Make sure the components are clean and free of damage.
- Store the components in a cool, clean, dry room.
- After making sure everything is present and in good condition, keep the components in original packages as long as possible.

## Position of Components

The position and amount of components are determined by three factors: burner design, system design, and the control method that you choose. All three factors are considered in the "System Design" chapter of the AH-MA AirHeat Burner Design Guide No. 160. Use the information in that chapter to build your system.

## Approval of Components

### **Limit Controls & Safety Equipment**

All limit controls and safety equipment must comply with all applicable local codes and/or standards and must be listed for combustion safety by an independent testing agency. Typical application examples include:

- American: NFPA 86 with listing marks from UL, FM, CSA
- European: EN 746-2 with CE mark from TuV, Gastec, Advantica

### **Electrical Wiring**

All the electrical wiring must comply with all applicable local codes and/or standards such as:

- NFPA Standard 70
- IEC60364
- CSA C22
- BS7671

### **Gas Piping**

All the gas piping must comply with all applicable local codes and/or standards such as:

- NFPA Standard 54
- ANSI Z223
- EN 746-2

### **Where to Get the Standards:**

#### **The NFPA Standards are available from:**

National Fire Protection Agency  
Batterymarch Park  
Quincy, MA 02269  
[www.nfpa.org](http://www.nfpa.org)

#### **The ANSI Standards are available from:**

American National Standard Institute  
1430 Broadway  
New York, NY 10018  
[www.ansi.org](http://www.ansi.org)

#### **The UL Standards are available from:**

333 Pfingsten Road  
Northbrook, IL 60062  
[www.ul.com](http://www.ul.com)

**The FM Standards are available from:**

1151 Boston-Providence Turnpike  
PO Box 9102  
Norwood, MA 02062  
www.fmglobal.com/approvals

**Information on the EN standards and where to get them is available from:**

Comité Européen de Normalisation  
Stassartstraat 36  
B-1050 Brussels  
Phone: +32-25196811  
Fax: +32-25196819  
www.cen.eu

Comité Européen de Normalisation Electronique  
Stassartstraat 36  
B-1050 Brussels  
Phone: +32-25196871  
Fax: +32-25196919  
www.cenelec.org

**Checklist Before Installation**

**Access**

Make sure that you install the system in such a way that you can get easy access to the burner for inspection and maintenance.

**Environment**

Make sure that the local environment matches the original operating specifications. Check the following items:

- Voltage, frequency and stability of the electrical power
- Fuel type and supply pressure of the fuel
- Availability of enough fresh, clean combustion air
- Humidity, altitude and temperature of air

- Presence of damaging corrosive gases in the air

**Duct Configuration**

When laying out the duct, allow enough length downstream of the burner to avoid flame impingement; see page 3 of the Data Sheet No. 160 for flame lengths. To improve temperature uniformity, this distance should be increased or a flow distribution plate used, as shown in Figure 3.1.

**NOTE:** Use the following distances between the burner and transition duct when temperature uniformity is essential. For rectangular ducts: either the width or height of one duct section (whichever is greater), or for circular ducts: the diameter of one duct section.

**Suspending the Burner**

Eclipse AH-MA AirHeat burners must be securely supported to avoid misalignment of the burner in the duct; see Figure 3.2 for support examples.



- Supports should allow for thermal expansion of the burner and duct as the temperature of the components increase. Piping expansion joints should be used outside of the duct to accommodate movement of the duct section when heated.
- Avoid large obstructions in the air flow from support causing uneven air flow into the burner. Use low profile supports such as flat iron to minimize flow disturbances.

**NOTE:** On pipe or manifold support examples, locate the main support as close as possible to the burner assembly's center of gravity to minimize the load.

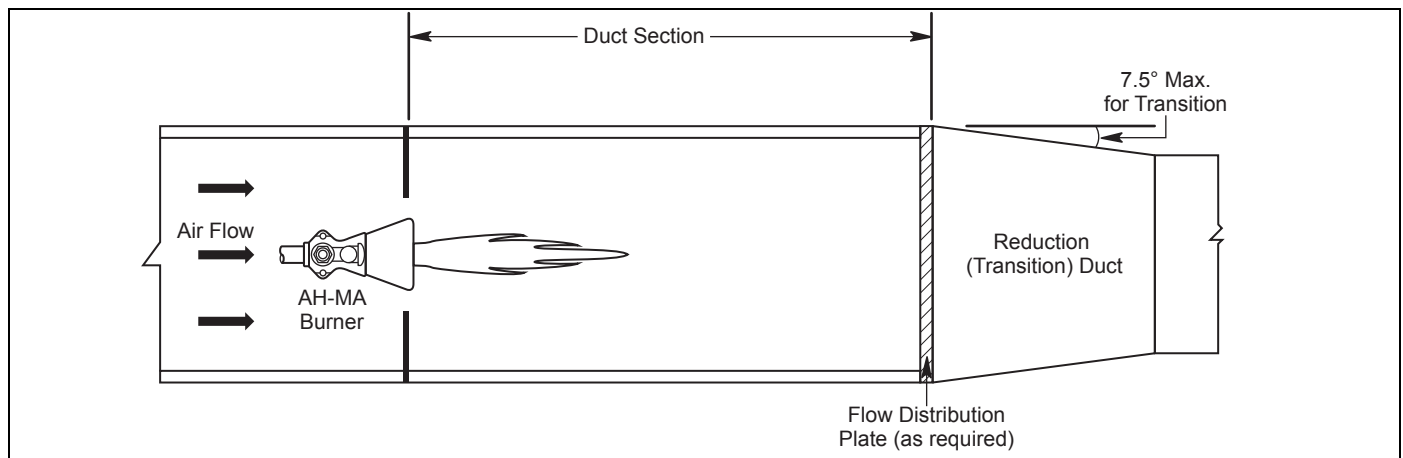

**Figure 3.1 Duct Configuration**



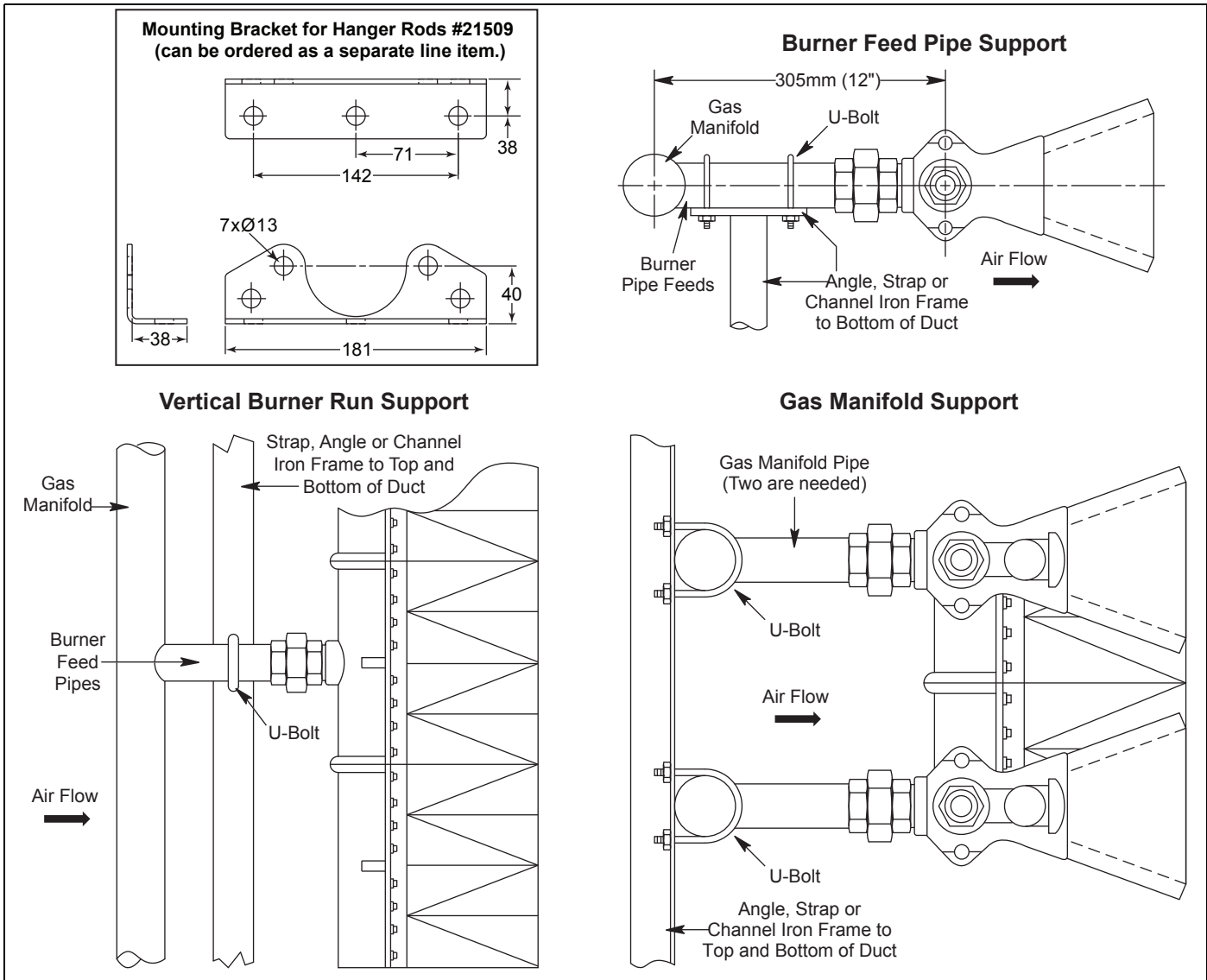

**Figure 3.2 Burner and Pipe Support Examples**

**Prepare the Burner**

There are several components that must be installed to a burner system before it can operate. Instructions to do that follow below:

**Adjust the Profile Plates**

Profile plates should be adjusted to their initial position; see Figure 3.3.



- Profile plates should be positioned upstream of the firing end of the burner. If necessary, the plates can be located up to 1" back from the firing end, but under no circumstances should they be in front of the burner.

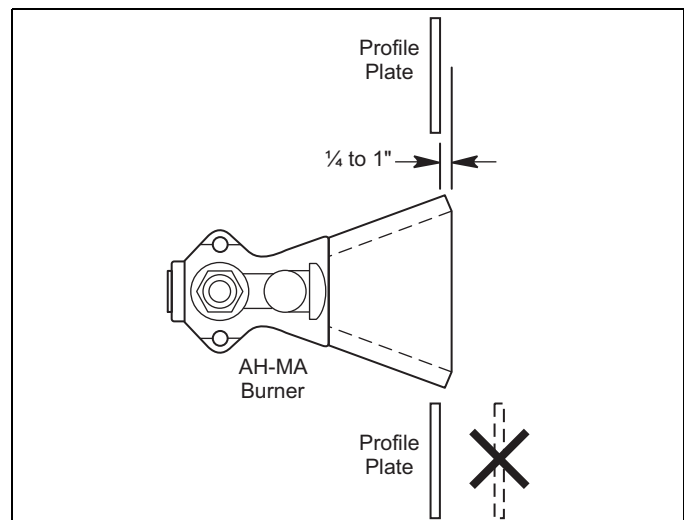

**Figure 3.3 Profile Plate Position**



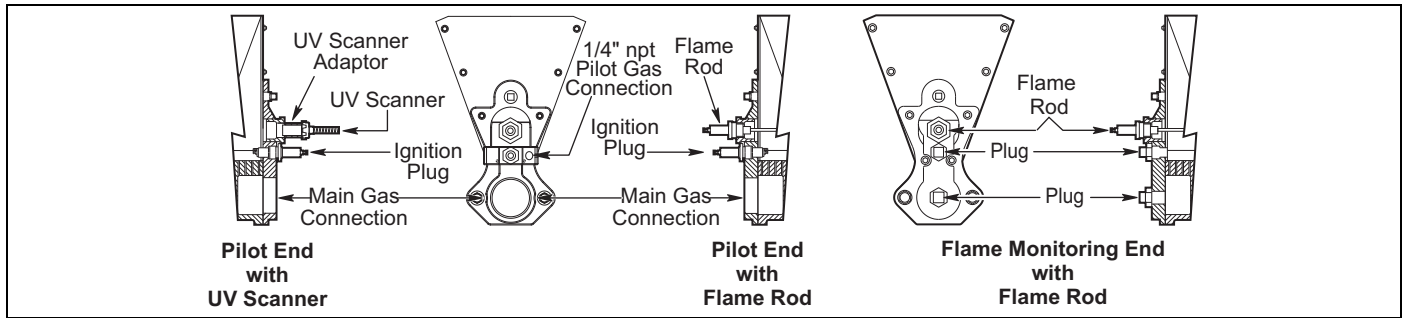

Figure 3.4 End Plate Examples (Shown with Optional UV, Flamerod, and Spark Plug Installed)

## Install the Flame Sensor

1. Depending on the chosen flame sensor, locate and install it into the corresponding opening located in the end plate as shown in Figure 3.4.
2. Make sure that you connect the flame sensor of a burner to the electrical circuit of the burner.



- **If you connect the flame sensor of a burner to the electrical circuit of the wrong burner, then you can cause fires and explosions.**

There are two different types of flame sensors:

### UV Scanner:

For detailed information on how to install and connect a UV scanner, refer to:

- Bulletin/Instruction Manual 854 for straight UV scanners
- Bulletin/Instruction Manual 852 for 90° UV scanners
- Bulletin/Instruction Manual 956 for self-check UV scanners

### Flamerod:

For detailed information on how to install and connect a flamerod, refer to Bulletin/Info Guide 832.

## Install the Spark Plug

Install the spark (ignition) plug into the appropriate opening of the end plate as shown in Figure 3.4.

**NOTE:** DO NOT apply any grease to the threads of the spark plug. You can cause bad grounding of the spark plug if you apply grease to it. Bad grounding of the spark plug results in a weak spark.

## Piping

### Piping Layout

Install all piping as shown in Figure 3.5.

### Support the Piping

Use brackets or hangers to support the piping. If you have questions, consult your local gas company.

### Piping Connections

1. Install a pipe union in the line to each burner. This simplifies removal of the burner.
2. The use of flexible pipe nipples in gas lines to the burner is optional. Flexible nipples can absorb stresses due to heat expansion.
3. Flexible pipe nipples may cause higher pressure drops than equivalent standard pipes. Consider that when you size the air lines.
4. Install pressure taps in the main and pilot gas lines as shown.

### Avoid Large Pressure Drops

**NOTE:** The pressure drop of the gas in the piping is a critical parameter. Make sure that the size of all the piping is large enough to prevent excessive pressure losses.

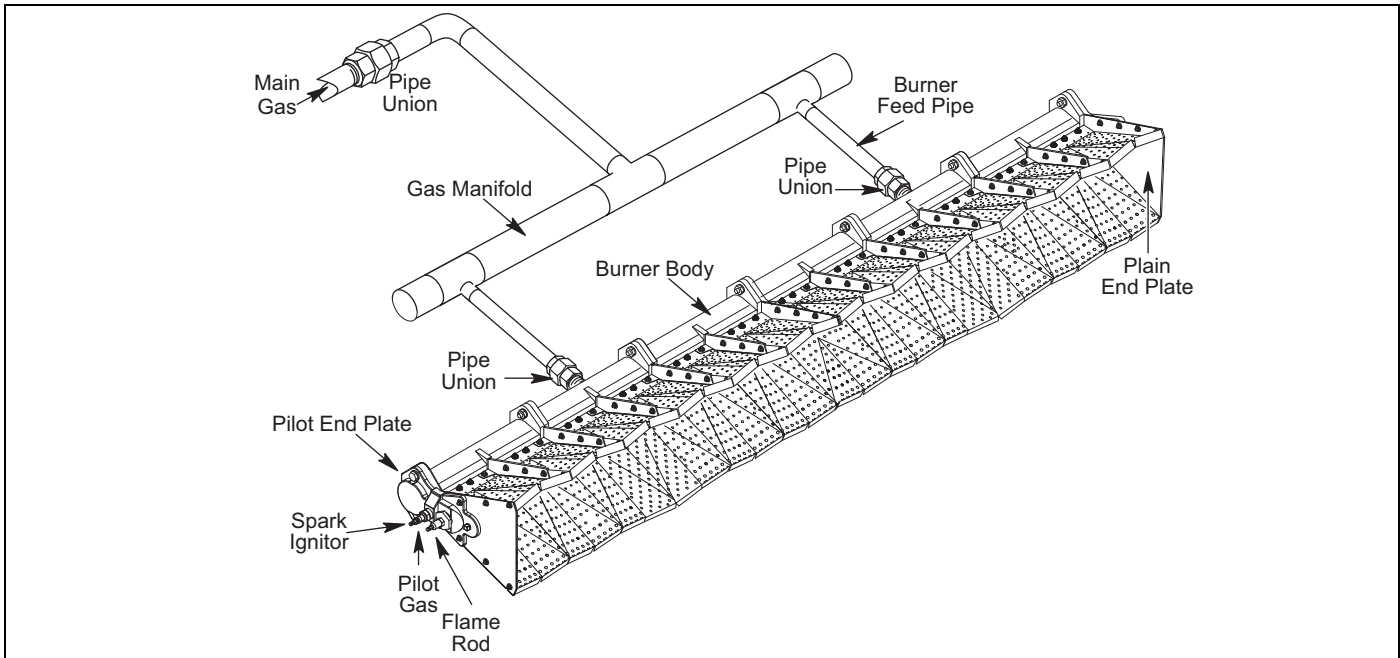

**Figure 3.5 Gas Piping and Layout**

### **Checklist After Installation**

1. Make sure that there are no leaks in the gas lines.
2. Make sure that the blower rotates in the correct direction. If incorrect, then have a qualified electrician rewire the blower to reverse its rotation.
3. Set the air proving switch.
4. Set the low gas pressure switch at 4" w.c. below the gas pressure that you measure at the inlet to the main gas valve train.
5. Set the high gas pressure switch at 4" w.c. above the gas pressure that you measure at the inlet to the main gas valve train.
6. Close all the burner gas cocks.
7. Trip out pressure switches and other limit interlocks. Make sure that the main gas valves close.

**! DANGER**

- **If simulated limits or simulated flame failures do not shut down the fuel system within the required failure response time, then immediately correct the problem.**

# Adjustment, Start & Stop

# 4

## Introduction

In this chapter you will find instructions on how to adjust a system and how to start and stop a system.



- Do not bypass any safety features. You can cause fires and explosions.
- Obey the safety precautions in the Safety chapter.

## Adjustment Procedure

**NOTE:** Adjustment requires two manuals: this Installation Guide and Datasheet No. 160. This chapter refers to component information which is found in Datasheet 160.

Read all of this chapter before starting your system.

### Step 1: Reset the System

If you are adjusting the burner system for the first time, then you must follow these steps:

1. Reset the system
2. Set air pressure drop
3. Verify the air setting
4. Ignite the pilot
5. Ignite the burner
6. Set low fire gas
7. Set high fire gas
8. Verify the gas settings

Close the automatic gas valves and the gas cocks.

### Step 2: Set Air Pressure Drop

1. Start the main fan on the make-up or process air unit.
2. Set the fan inlet damper or profile plates to produce the desired pressure drop across the burner. Air pressure drop can be read as a differential pressure across the burner using a U-Tube manometer as shown.

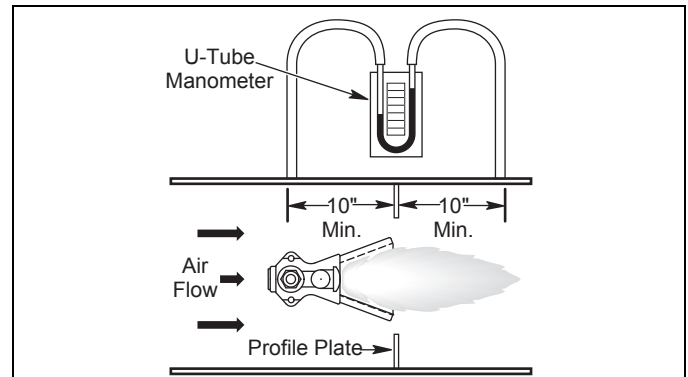

Figure 4.1

### Step 3: Verify the Air Settings

Make sure that all the settings are still the same after you cycle the system several times between high fire and low fire. Check air proving switch and adjust if necessary.

**NOTE:** Test spark ignitor with a visual or audible check before attempting ignition.

### Step 4: Ignite Pilot

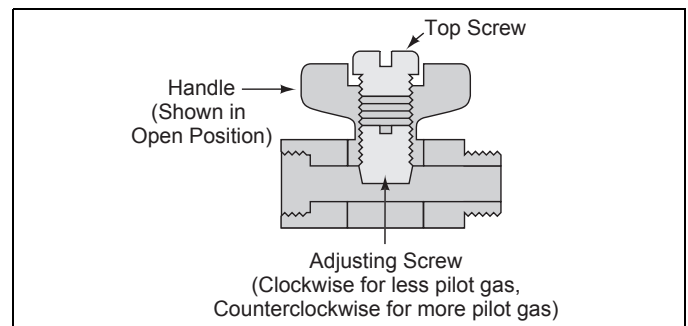

Figure 4.2 Pilot Adjusting Valve

1. Set system to operate on pilot only. See the literature included with the flame monitoring relay.
2. Set pilot regulator to 6" w.c. outlet pressure.
3. Open the pilot adjusting valve 3 to 4 turns. (PN 12659 ordered separately.)
4. Initiate start sequence and ignite the pilot.

**NOTE:** Initially it may be necessary to repeat step 4 two or three times to purge air out of the gas pipework.

- Trim pilot with adjustable gas cock to obtain flame just inside air wings.

**NOTE:** The pilot flame should be a bushy, blue flame inside the first one-fourth of the air wings. This flame should provide a stable pilot with good flame signal readings sufficient to energize the main gas valve.

### **Step 5: Ignite the Burner**

**NOTE:** This procedure assumes that automatic flame safety is installed and is serviceable.

- Make sure the supply air fan is running.
- Adjust the main gas regulator to supply the minimum pressure required; see Datasheet No. 160 for gas pressure drop and measurement information.
- Verify that the main gas control valve is at its minimum open position (5°).
- Light the pilot.
- Open all manual fuel shut-off valves.
- Initiate the ignition sequence through the flame safety.
- Check that the pilot and then burner flames have ignited.

**NOTE:** The input required to ignite the main burner will be more than the minimum input capability of the burner given in Datasheet No. 160. Nominally, an input of 50,000 BTU/hr/ft is required for ignition of the main burner.

### **Step 6: Adjust Low Fire Gas**

If necessary, adjust the main gas control valve's minimum open position until the low fire flame is tight against the base of the burner body and is uniform along the length of the burner.

### **Step 7: Adjust High Fire Gas**

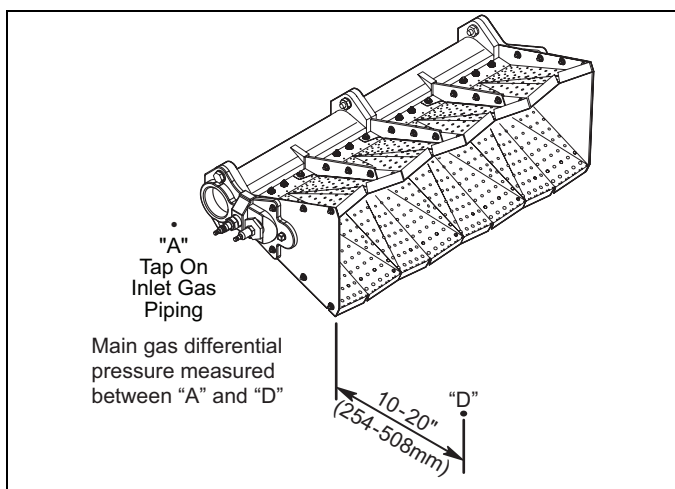

**Figure 4.3**

- Drive the main gas control valve to high fire.
- Measure the gas pressure drop at high fire and compare to the appropriate chart in Datasheet No. 160. If the maximum input is not achieved or is too high while the main gas control valve is fully open, two adjustments can be made:
  - The manual butterfly valve in the gas line can be adjusted open or closed, or
  - The main gas pressure regulator can be adjusted higher or lower.



**DANGER**

- Make sure that you close all the pressure taps after you remove the manometer. Gas that leaks from the pressure taps can cause fires and explosions.

### **Step 8: Verify Gas Settings**

- Once the high and low fire conditions have been set, cycle the burner from high to low fire several times to check repeatability of settings.
- Shut down the burner and relight to ensure automated pilot and main flame ignition operates correctly.
- Check all safety interlocks and limits to ensure proper operation.
- Make sure that all the settings are still the same after you cycle the system several times between high fire and low fire.
- When all settings have been completed, mark the position of the position indicator on each butterfly valve to indicate valve position. This will save time later.

### **Start Procedure**

- Start the air supply fan.
- Open all the gas cocks.
- Start the automatic ignition sequence.



**DANGER**

- If a burner does not light, and the system does not shut down automatically then you must close the main gas cock. An uncontrolled flow of gas can cause fires and explosions.
- Do not touch the ignition plug or the ignition wire when the ignition is on. You will get a shock.

4. Make sure that you can see the flame in the burner system.

**If the burner system does not light and does not shut down automatically**, close the main gas cock manually. DO NOT operate the system. Go to "Checklist After Installation" and verify the steps. After that, repeat the start procedure.

**If the burner system does not light and shut downs automatically**, see the troubleshooting section in the next chapter.

### **Stop Procedure**

To stop, close the following valves:

- the manual gas cock for the burner
- the manual gas cock at the main control valve
- all of the manual shut-off valves in the gas line upstream of the burner gas cock

# Maintenance & Troubleshooting

# 5

## **Introduction**

This section is divided into two parts:

- the first part describes the maintenance procedures
- the second part helps you to identify problems that may occur, and gives advice on how to solve these problem

## **Maintenance**

Preventative maintenance is the key to a reliable, safe and efficient system. The following are suggested guidelines for periodic maintenance. Burners in severe environments or operational conditions should be checked more frequently.

**NOTE:** The monthly and yearly lists are an average interval. If your environment is dirty, then the intervals may be shorter. Check with local authorities having jurisdiction on their recommended maintenance schedules.



**CAUTION**

- **Turn off power to burner and controls before proceeding with burner inspection.**

## **Monthly Checklist**

1. Inspect flame sensing devices for good condition and cleanliness.
2. Test all alarms for proper signals.
3. Check ignition spark electrode operation and check proper gap.
4. Check all valve motors and control valves for free, smooth action and adjustment.

5. Test interlock sequence of all safety equipment and manually make each interlock fail, noting that related equipment closes and stops as specified by the manufacturer. Test flame safeguard by manually shutting off gas to burner.
6. Test all manual fuel valves for operation.
7. Check filters on main air fan for cleanliness.
8. Check gas filter or strainers.

## **Yearly Checklist**

1. Test (leak test) safety shut-off valves for tightness of closure.
2. Test pressure switch settings by checking switch movements against pressure settings.
3. Visually check ignition cable and connectors.
4. Inspect gas injection holes and burner mounting structure.
5. Check profile plate position against final position from initial setup.
6. Check all screws and bolts holding air wings to each other and to the burner bodies.
7. Inspect both sides to ensure no air holes are blocked and that there is no build up of foreign material on the wings.
8. Inspect air wings for distortion and bending. Excessive distress may indicate a non-uniform pressure drop/velocity or operation outside of the recommended limits on input and velocity. Replace air wings as necessary.

<b>Problem</b>	<b>Possible Cause</b>	<b>Solution</b>
Cannot initiate start-up sequence	Air pressure switch has not made contact; Air flow too low	Check air flow and investigate any changes.
	Air pressure switch has not made contact; Air pressure switch incorrectly set	Check air pressure switch adjustment.
	Air pressure switch has not made contact; Air pressure drop measured incorrectly	Move pressure taps on duct to a better location.
Cannot initiate start-up sequence	High gas pressure switch has tripped; Gas pressure too high	Check incoming gas pressure against initial setting; adjust as required.
	High gas pressure switch has tripped; Gas pressure switch set too low	Adjust setting to be approximately 4" w.c. above gas pressure.
	Low gas pressure switch has tripped; Gas pressure too low.	Check incoming gas pressure against initial settings; adjust as required
	Low gas pressure switch has tripped; Gas pressure switch set too high	Adjust setting to be approximately 4" w.c. below gas pressure.
	Purge cycle not completed	Check flame safeguard system or purge timer.
	Main power is off	Make sure power is on to control system.
	No power to control unit	Call qualified electrician to investigate.
	Malfunction of flame safeguard system; Flame sensor shorted out	Ensure flame rod element is not touching burner; check UV sensor and wiring.
	Malfunction of flame safeguard system; Electrical noise in sensor line	Shield or separate sensor lines from high voltage.
	Malfunction of flame safeguard system; Unit is broken	Call qualified electrician to investigate.
Start-up sequence runs but pilot does not light	No spark; No power to ignition transformer	Have electrician investigate.
	No spark; Open circuit between the ignition transformer and the spark plug	Repair or replace wiring to spark plug.
	No spark; Spark plug has carbon build-up	Clean or replace spark plug.
	No spark; Spark plug not correctly grounded	Clean spark plug threads. Do not apply grease or pipe compound to pipe threads.
	No spark; Spark plug gap is incorrect	Set gap to specifications.
	Not enough pilot gas; Pilot gas regulator set too low	Check incoming gas pressure against initial settings; increase as necessary.
	Not enough pilot gas; Gas pressure into pilot regulator too low	Check outgoing gas pressure of main regulator; increase as necessary.
	Not enough pilot gas; Pilot gas cock closed	Open pilot gas cock.
	Not enough pilot gas; Pilot solenoid valve does not open	Have qualified electrician check power supply to solenoid.
	Not enough pilot gas; Gas adjusting valve set too low	Adjust gas flows
	Not enough pilot gas; Air in the gas line	Repeat start-up several times to purge air out of gas lines.
	Not enough pilot gas; Gas is leaking from pilot end plate	Check bolts and tighten as necessary.
	Too much gas	Trim pilot gas adjusting valve.
Start-up sequence runs, pilot lights but main burner does not light	No flamerod or UV signal	Check wiring and control logic.
	Not enough main gas; Main gas regulator set too low	Check outgoing gas pressure of main regulator; increase as necessary
	Not enough main gas; Gas pressure into main regulator to low	Check incoming gas pressure against initial settings; increase as necessary



<b>Problem</b>	<b>Possible Cause</b>	<b>Solution</b>
Start-up sequence runs, pilot lights but main burner does not light	Not enough main gas; Main gas cock closed	Open all gas cocks.
	Not enough main gas; Main safety shut-off valve does not open	Have qualified electrician check power supply and safety circuitry.
	Not enough main gas; Gas adjusting valve set too low.	Adjust gas flows.
	Not enough main gas; Air in the gas line	Repeat start-up several times.
	Too much gas	Trim pilot gas adjusting valve.
Pilot ignites but flame safeguard shuts down burner	No flamerod or UV signal	Check wiring and control logic.
Burner kicks out shortly after start-up	Low gas pressure switch is set too high	Check and reset low pressure switch setting.
The low fire flame is weak and unstable	Not enough gas	Check startup settings and adjust to increase gas flow.
	Too much air	Check air pressure drops / velocities across the burner and adjust.
	Poor distribution of main gas	Ensure proper number of gas feeds are used. Ensure manifold is sized properly. Refer to Design Guide No. 160 for recommendations.
	Poor air distribution	Check profiling and duct configuration.
Burner does not go to high fire	Not enough gas pressure into main gas regulator	Adjust pressure regulator so pressure is provided at burner as specified in this manual.
	Gas pressure drops as input is increased	Check for clogging of valves and regulators in gas line.
	Main gas control valve is not functioning	Check actuator and linkage.
Main flame is uneven along the length of the burner	Air pressure drop / velocity is too low	Increase air pressure drop.
	Poor air distribution	Check profiling and duct obstructions.
	Air wings are dirty, holes are clogged	Inspect and clean the air wings if necessary,
	Poor distribution of main gas	Ensure proper number of gas feeds are used. Ensure manifold is sized properly; refer to Design Guide No. 160 for recommendations.
Main flame is too large at high fire	Gas pressure too high at burner inlet	Check gas pressure against design. Adjust main gas pressure regulator, or adjust manual adjusting valve.
	Air pressure drop/velocity is too high	Open air damper on main air blower or adjust profile plates.
Main flame does not achieve capacity	Air pressure drop/velocity is too high	Check pressure drop or velocity. Check air damper on main air blower.
	Burner is firing below rated input	Check gas pressure differential. Adjust main gas pressure regulator as necessary.
	Burner gas holes are plugged	Inspect gas holes for dirt or lint; clean as needed.
Main flame is yellow and long	Air pressure drop/velocity is lower than design	Check pressure drop or velocity. Open air damper on main air blower.
	Air wings are dirty, holes are clogged	Inspect and clean the air wings if necessary.

# Straight Section Parts List

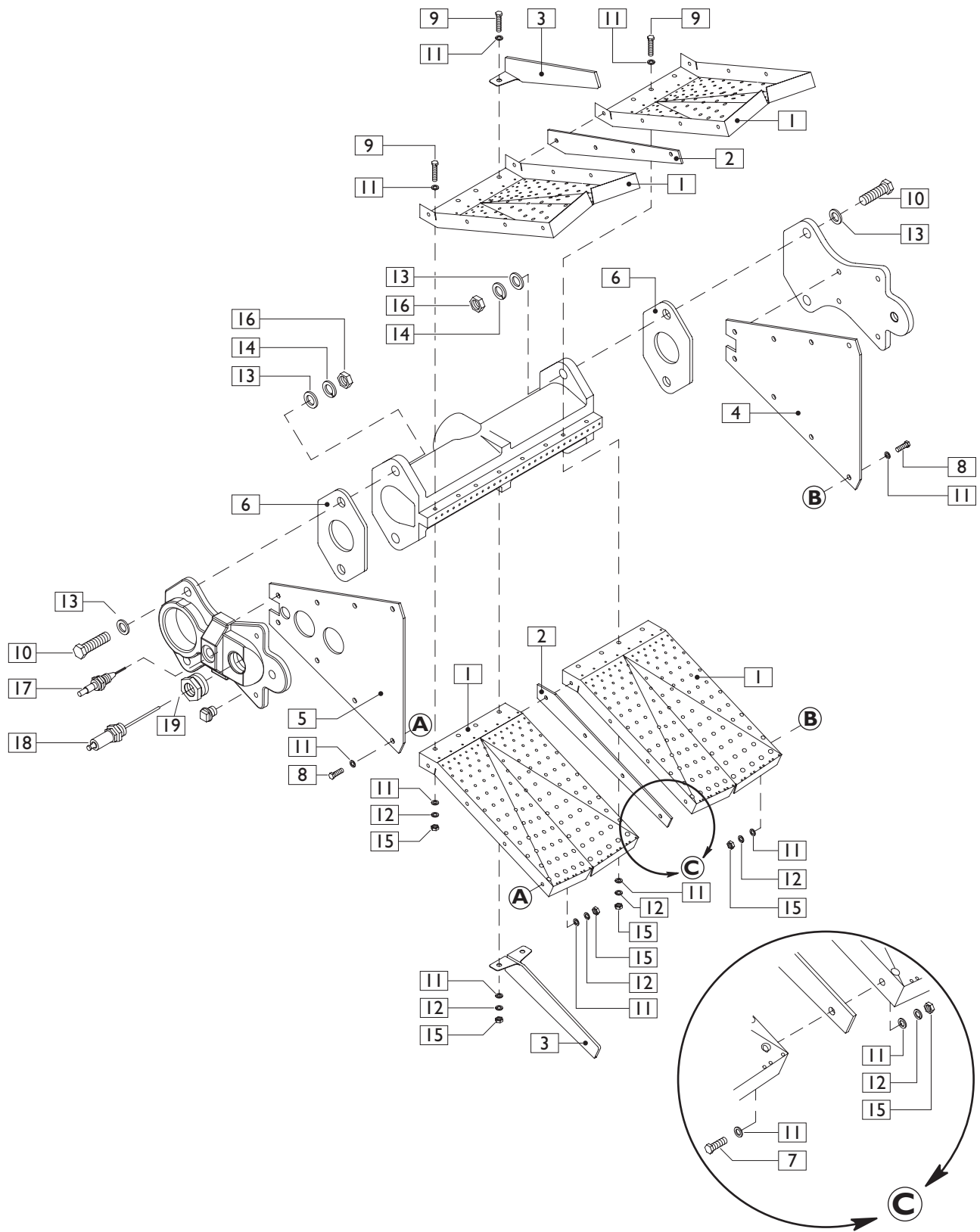

# Tee Section Parts List

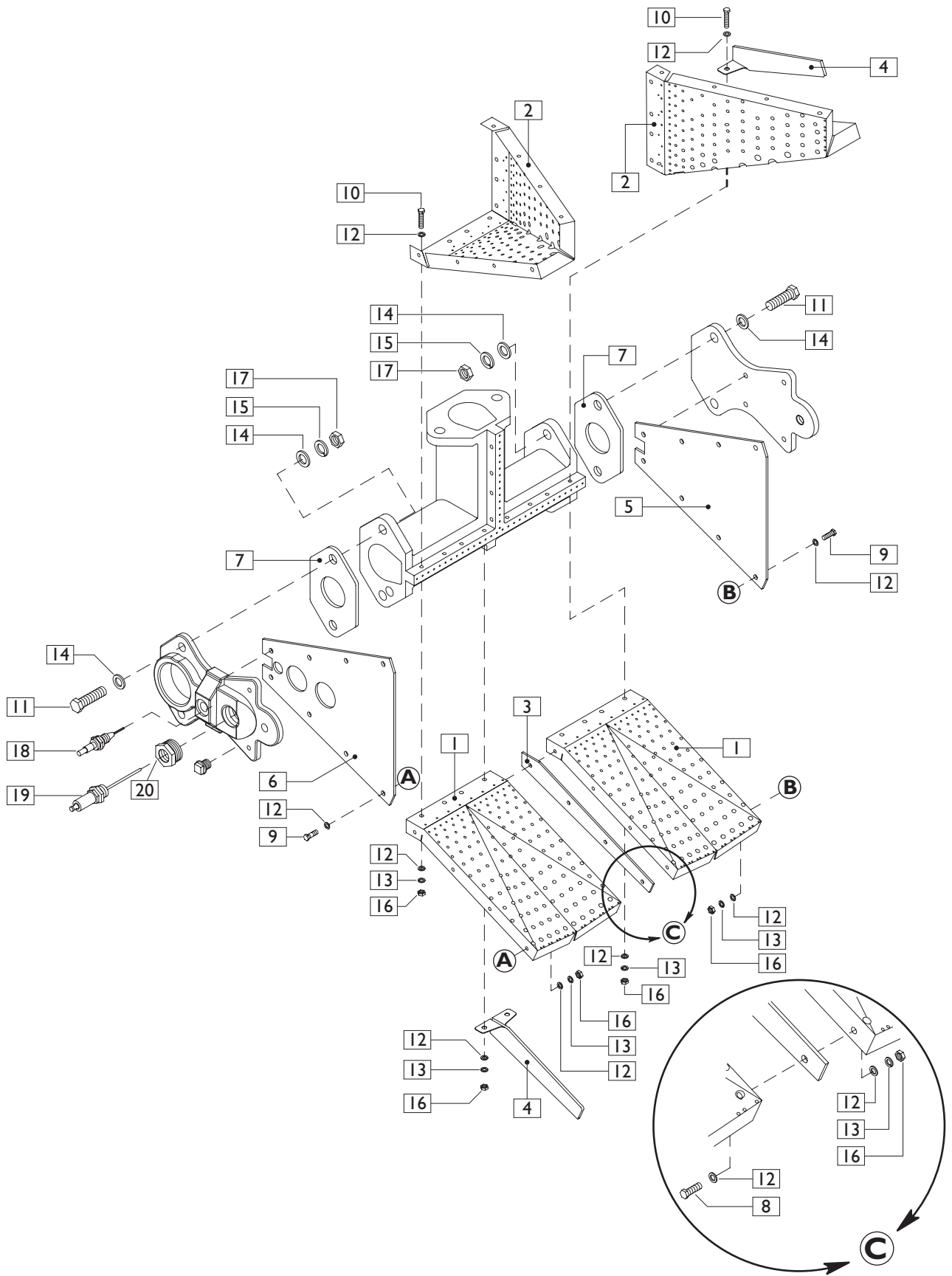

## Straight Section Parts List

Ref No.	Qty	Description	Part No.
1	4	Straight Air Wing	76501
2	2	Air Wing Joint Bracket	76507
3	2	Air Wing Reinforcement Plate	76505
4	1	Plain End Plate	76504
5	1	Pilot End Plate	76503
6	2	End Plate Gasket	76510
7	8	Screw, M4 x 12, Hex Head	20394
8	8	Screw, M4 x 20, Hex Head	20395
9	8	Screw, M4 x 25, Hex Head	20335
10	4	Screw, M10 x 40, Hex Head	20336
11	48	Washer, M4, Flat	90787
12	24	Washer, M4, Lock	20244
13	8	Washer, M10, Flat	90768
14	4	Washer, M10, Lock	15890
15	24	Nut, M4	90786
16	4	Nut, M10	15889
17	1	Spark Plug	13047-1
18	1	Flame Rod	13093
19	1	UV Adapter, 1/2"	202010
19	1	UV Adapter, 3/4"	202011
20*	1	Gas Cock, Adjustable 1/4"	12659
* Not shown			

## Tee Section Parts List

Ref No.	Qty	Description	Part No.
1	2	Straight Air Wing	76501
2	2	Air Wing Joint	76502
3	1	Air Wing Joint Bracket	76507
4	1	Air Wing Reinforcement Plate	76505
5	1	Plain End Plate	76504
6	1	Pilot End Plate	76503
7	2	End Plate Gasket	76510
8	8	Screw, M4 x 12, Hex Head	20394
9	8	Screw, M4 x 20, Hex Head	20395
10	12	Screw, M4 x 25, Hex Head	20335
11	4	Screw, M10 x 40, Hex Head	20336
12	56	Washer, M4, Flat	90787
13	28	Washer, M4, Lock	20244
14	8	Washer, M10, Flat	90768
15	4	Washer, M10, Lock	15890
16	28	Nut, M4	90786
17	4	Nut, M10	15889
18	1	Spark Plug	13047-1
19	1	Flame Rod	13093
20	1	UV Adapter, 1/2"	202010
20	1	UV Adapter, 3/4"	202011
21*	1	Gas Cock, Adjustable 1/4"	12659
* Not shown			

## Recommended Spare Parts Section

To make sure that the downtime of the system is as short as possible in case of a failure, you should keep a stock of spare parts.

### **Recommended spare parts:**

- Spark Plug
- Flame Rod
- UV Scanner (if used)
- End Plate Gasket



# Appendix

## Conversion Factors

### Metric to English

From	To	Multiply By
actual cubic meter/hr (am <sup>3</sup> /h)	actual cubic foot/hr (acfh)	35.31
normal cubic meter/hr (Nm <sup>3</sup> /h)	standard cubic foot /hr (scfh)	38.04
degrees Celsius (°C)	degrees Fahrenheit (°F)	(°C x 9/5) + 32
kilogram (kg)	pound (lb)	2.205
kilowatt (kW)	BTU/hr	3415
meter (m)	foot (ft)	3.281
millibar (mbar)	inches water column ("w.c.)	0.402
millibar (mbar)	pounds/sq in (psi)	14.5 x 10 <sup>-3</sup>
millimeter (mm)	inch (in)	3.94 x 10 <sup>-2</sup>
MJ/Nm <sup>3</sup>	BTU/ft <sup>3</sup> (standard)	26.86

### Metric to Metric

From	To	Multiply By
kiloPascals (kPa)	millibar (mbar)	10
meter (m)	millimeter (mm)	1000
millibar (mbar)	kiloPascals (kPa)	0.1
millimeter (mm)	meter (m)	0.001

### English to Metric

From	To	Multiply By
actual cubic foot/hr (acfh)	actual cubic meter/hr (am <sup>3</sup> /h)	2.832 x 10 <sup>-2</sup>
standard cubic foot /hr (scfh)	normal cubic meter/hr (Nm <sup>3</sup> /h)	2.629 x 10 <sup>-2</sup>
degrees Fahrenheit (°F)	degrees Celsius (°C)	(°F - 32) x 5/9
pound (lb)	kilogram (kg)	0.454
BTU/hr	kilowatt (kW)	0.293 x 10 <sup>-3</sup>
foot (ft)	meter (m)	0.3048
inches water column ("w.c.)	millibar (mbar)	2.489
pounds/sq in (psi)	millibar (mbar)	68.95
inch (in)	millimeter (mm)	25.4
BTU/ft <sup>3</sup> (standard)	MJ/Nm <sup>3</sup>	37.2 x 10 <sup>-3</sup>



# System Summary

Write down the settings for the burner system in the table that follows:

General System Parameters	Burner Settings	
	High Fire	Low Fire
Customer:	Main gas pressure:	
Customer PO:	Air pressure from the blower:	
Customer Signature	Air pressure drop across the burner:	
Dates:	Gas pressure drop across the burner:	
Furnace Type:	Flame signal strength:	
Furnace Temperature:	Flame length:	
Number of Burners:		
High Fire Input Per Burner:		
Orifice Size:		
Operating Voltage and Frequency:		
Altitude:		

